

Flywheel Replacement – 1991 40 (4 Cylinder)

1991 Mariner and Mercury 40 (4 Cylinder)
Serial Number

US 0D055048 thru 0D071436
Belgium 9665165 thru 9670909

Outboards listed, require replacement of the cast iron flywheel, (Figure 1) with a new style flex plate flywheel (Figure 2). The cast iron flywheel has the potential to cause the crankshaft to flex under certain load/engine speed conditions, resulting in damage to the labyrinth seal of the upper reed block.

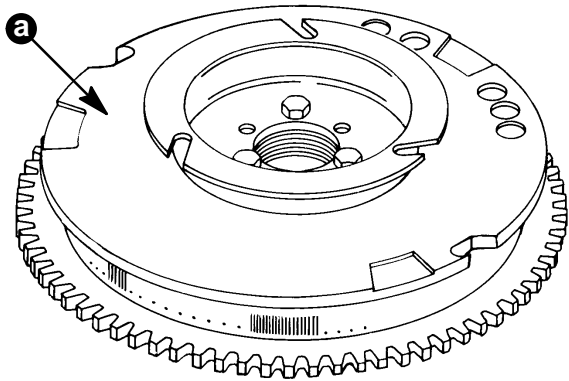

51445

a - Cast Iron Flywheel (No Flex Plate) - Must be Replaced

Figure 1. Cast Iron Flywheel

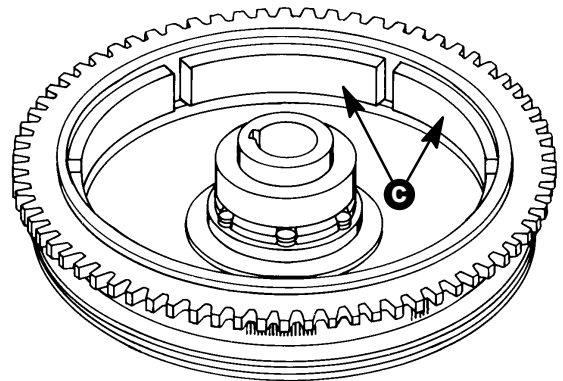
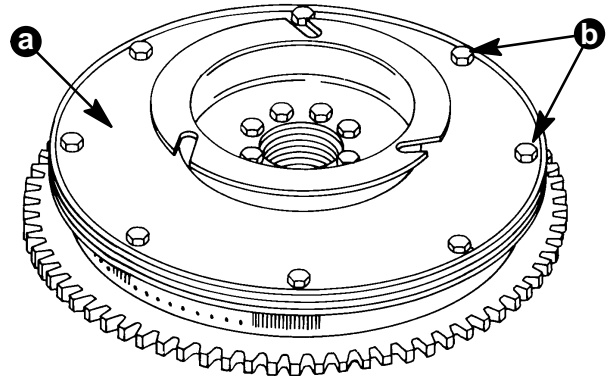

51447

- a - Flex Plate
- b - Bolts
- c - Magnets - Glued in Place

Figure 2. New Style Flex Plate Flywheel

DO NOT use the earlier style flex plate flywheel (Figure 3) on models listed, as the polarity of the flywheel magnets is not compatible with the present stators.

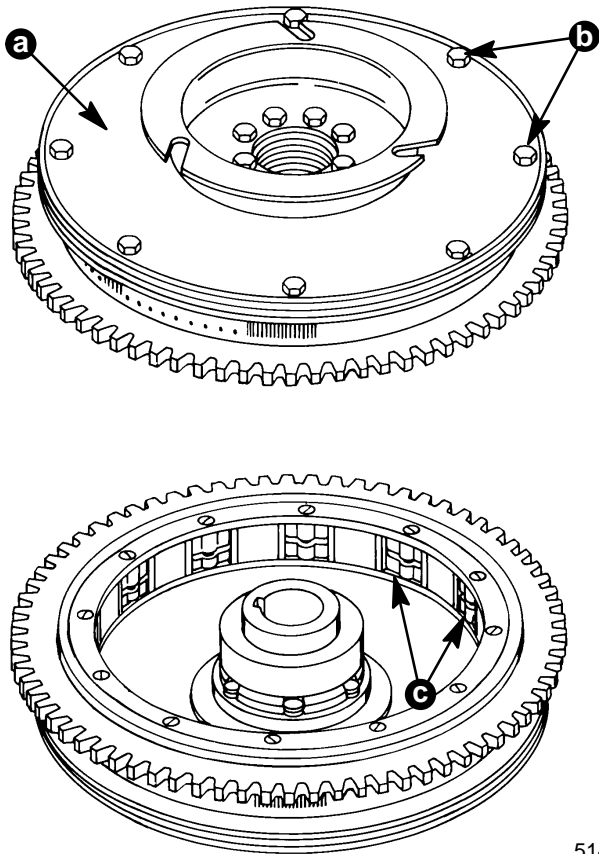

51446

- a - Flex Plate
- b - Bolts
- c - Magnets - Secured with Screws

Figure 3. Earlier Style Flex Plate Flywheel - Do Not Use On Models Listed

OWNER NOTIFICATION:

A letter will be sent to every registered owner of a 40 (4 cylinder) model within the above listed serial number range. The letter will advise the owner to return their outboard to the selling dealer for warranty replacement of the flywheel. A copy of the letter is attached to this Service Bulletin.

DEALER SERVICE PARTS STOCK:

Dealer service parts stock will not be affected, as no service replacement cast iron flywheels were shipped from Quicksilver.

DEALER OUTBOARD INVENTORY:

Outboards listed, which are in dealer inventory should be reworked prior to customer delivery.

PARTS REQUIRED:

Qty. 1 P/N 248-8722A13 Flywheel Assembly (MANUAL START)

-or-

Qty. 1 P/N 248-8722A15 Flywheel Assembly (ELECTRIC START)

CORRECTION:

1. Replace cast iron flywheel with new style flex plate flywheel. Refer to Section 2A of Service Manual P/N 90-814676 for flywheel removal and installation instructions. Torque flywheel nut to 75 lb. ft. (101.7 N-m).
2. Refer to Section 2C of service manual and perform steps as listed under "Timing/Synchronizing/Adjusting".
3. Scrap cast iron flywheel, as it must not be used.

WARRANTY:

Complete warranty claim listing:

Outboard Serial Number

Qty. 1 P/N 248-8722A13 Flywheel Assembly (MANUAL START)

-or-

Qty. 1 P/N 248-8722A15 Flywheel Assembly (ELECTRIC START)

One (1) hour labor

Warranty labor rate codes OE23 and OA18

Failure code 409 40

Outboards that have been in operation with a cast iron flywheel and exhibit poor idle quality that can not be adjusted, should be checked for a failed labyrinth seal in the upper reed block.

If an upper reed block labyrinth seal failure occurs within twenty-four months from the date of sale, the repairs will be covered under warranty.

Dear Mercury Marine Product Owner

Mercury Marine has determined that the 40 horsepower model you purchased, requires replacement of the flywheel. This flywheel has the potential to cause engine damage under certain load/engine speed conditions.

Contact your authorized dealer for replacement of the flywheel. This service will be provided at no charge to you. Your dealer was advised of this flywheel replacement in Service Bulletin 91-20.

Some flywheels were replaced at the factory and can be identified as illustrated on the reverse side of this letter.

We regret the inconvenience this service may have caused you. However, we have taken this action to ensure your boating enjoyment and continued satisfaction with our product.

Mercury Marine Service Department

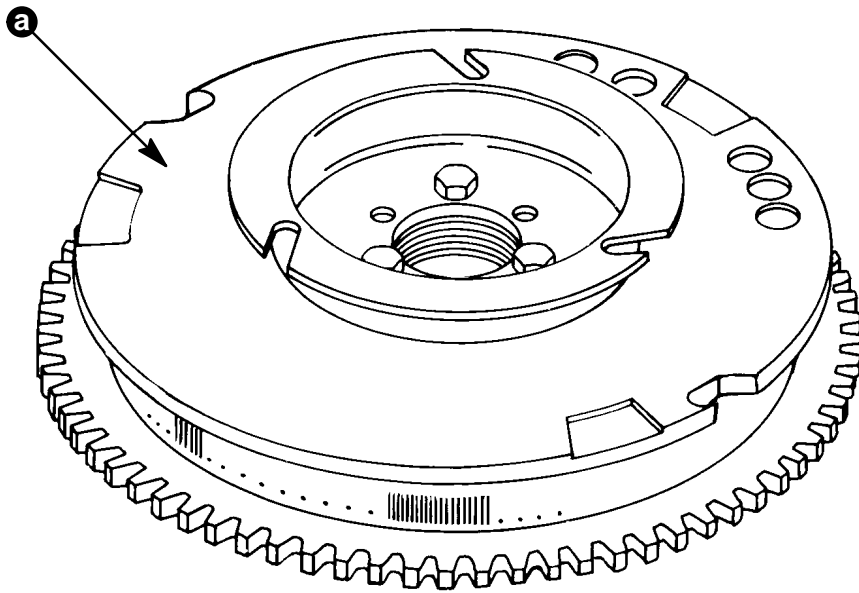

a - Cast Iron Flywheel (No Flex Plate or Bolts)

Figure 1. Cast Iron Flywheel Must Be Replaced

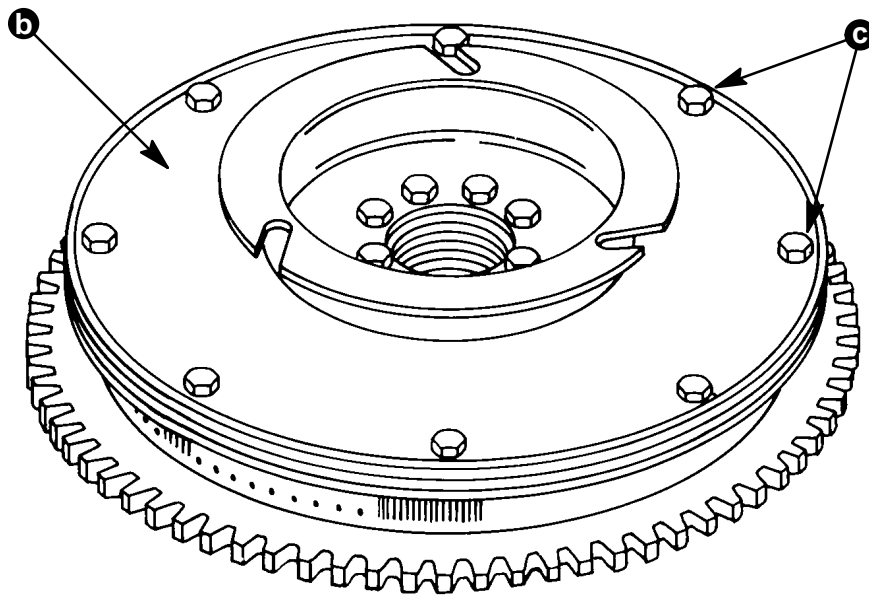

b - Flex Plate
c - Bolts

Figure 2. New Style Flex Flywheel - No Replacement Required