



service bulletin

No. 92-8

Revised 7-20-92

Slow Trim/Tilt Rate - 1992 75 thru 115

NOTICE

This is a revision of Outboard Service Bulletin 92-8. Destroy Bulletin 92-8 and insert Bulletin 92-8A. Revision is due to the change in the availability of P/N 811670 and 811670--1. Changes are underlined.

MARINER AND MERCURY

1992 75 thru 115

Single Ram Power Trim
with Date Code 11310 and Earlier

US S/N 0D082000 thru 0D136023

Belgium S/N 09682500 thru 09712813

Some single ram power trim units with date code 11310 and earlier may trim/tilt at a slower rate than designed. Refer to INSPECTION following to determine if the power trim unit is slower. Newer units with date code 11311 and later have recessed check valves to correct the slow trim/tilt rate.

At low temperatures the unit will trim/tilt at a slightly slower rate when operated the first time. Operating the unit through 4 - 5 cycles sufficiently warms the fluid and increases the trim/tilt rate.

Also, replacing the original 10W-30 oil with Quicksilver power trim and steering fluid p/n 92-90100A12 will reduce the initial cycle time for cold weather operation.

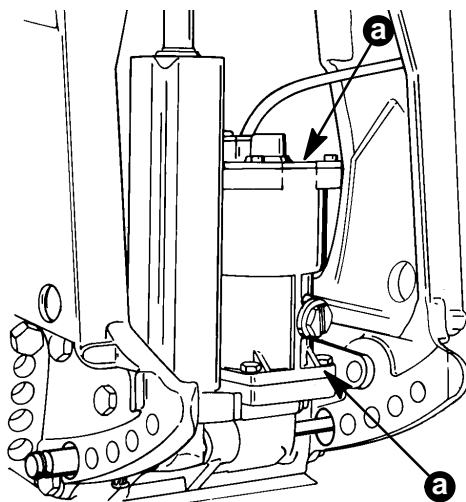

51485

a - Date Code Locations

Figure 1. Single Ram Power Trim

Date code on power trim:

1	1	3	1	1
Shift	Year	Day of the Year		
1	1991	November 7		

INSPECTION:

Measure the cycle time the power trim takes to move the outboard from full trim in to full tilt out. The cycle times listed are based on the temperature of the fluid and for the first time the trim is operated. Remember, after the trim unit has been operated, the fluid begins to warm and the unit will trim/tilt faster. To allow the fluid to cool to air temperature, the unit should stand for a minimum of two hours.

Replace pump/manifold if the cycle time is longer than:

28 seconds at 70° F (21° C).

or

40 seconds at 30° F (-1° C).

CORRECTION:

Replace pump/manifold using one of three improved service replacement assemblies. Pump/manifolds P/N 811670 with improved check valves are identified by a white dot on the bottom on the manifold. Pump manifolds P/N 811670--1 and 811670--2 have the check valve improvement and are identified by a green paint mark on the top of the manifold next to the trim/tilt cylinder mating surface as well as the white dot on the bottom of the manifold.

Power trim assemblies with date code 11311 and later, have the check valve improvement and have been in service stock since February 1, 1992.

Replace with:

P/N 811670 - Pump/Manifold which is NLA
White paint dot on the bottom

or

P/N 811670--1 - Pump/Manifold which is NLA
White paint dot on the bottom
Green paint mark on the top

or

P/N 811670--2 - Pump/Manifold with pilot relief valve
White paint dot on the bottom
Green paint mark on the top

Replacement of o-rings contained in seal kit p/n 25-811672A1 may not be necessary if the original ones are not damaged and the unit is fairly new.

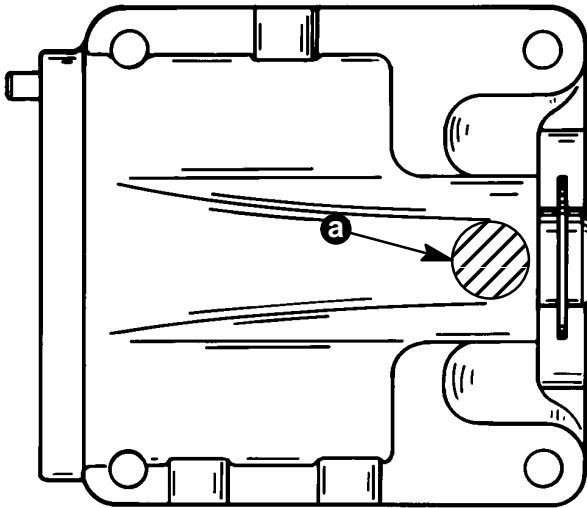

51765

a - Location of White Dot.

Figure 2. Bottom View of Pump/Manifold

WARRANTY:

Complete warranty claim listing:

Outboard serial number

Parts required

One (1) hour labor

Labor Rate Code OH21

Failure Code 111 15

US & Canada - Return pump/manifold with claim.

International - Hold parts for inspection/disposal by a Marine Power International technical representative.