

Carburetor Main Jet replacement 1993 - 200 Models

Mariner and Mercury

1993 200 Carburetor Models

S/N 0D182000 thru 0D223913

The outboards listed require the installation of larger main fuel jets on the top carburetor. The larger main jets will provide an extra margin of durability especially during engine break-in, during severe use or when using marginal or poor quality fuels.

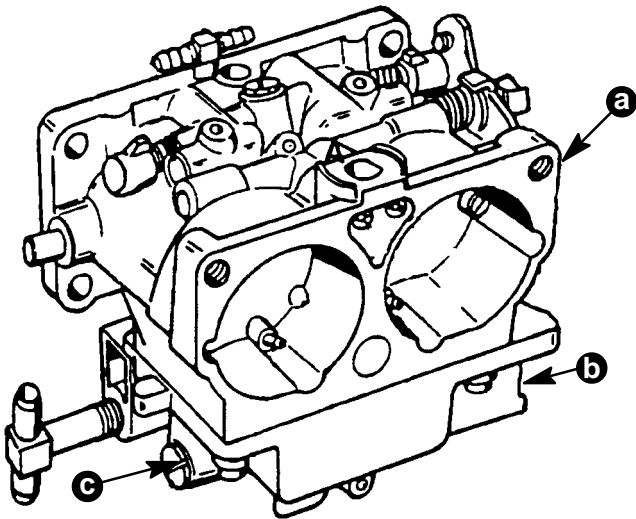

- a - Carburetor Number Location.
- b - Port Main Fuel Jet Access Plug (hidden).
- c - Starboard Main Fuel Jet Access Plug.

Figure 1. WMH Carburetor

OWNER NOTIFICATION:

USA/CANADA ONLY - All registered owners of the models affected will be sent a letter advising them of this situation. A copy of that letter is on the last page of this bulletin.

CORRECTION:

Install 0.066 main fuel jets in the top carburetor for #1 and #2 cylinders on the models listed. Remove both main fuel jet access plugs, gaskets and 0.064 main fuel jets from the top carburetor. Install 0.066 jets p/n 1399-4215. Reinstall both access plugs and gaskets. Check for fuel leaks.

PARTS REQUIRED:

Qty. 2 p/n 1399-4215 Main Jet (0.066 in.)

IDENTIFICATION:

Color the hex of both access plugs black. Stamp an "A" next to the carburetor number on the flat area on the upper port side (figure 1).

FACTORY REWORK IDENTIFICATION:

Outboards within the serial numbers listed that were reworked at the factory have:

- the hex of the access plugs colored black.
- the carburetors stamped 21-1A.
- an orange dot applied to the lower throttle arm.
- an orange dot on the outside of the outboard shipping carton next to the serial number.

SERVICE STOCK:

The carburetors with 0.064 main fuel jets were removed from stock, reworked and returned to stock with 0.066 jets installed. The service replacement number p/n 3311-818650A-4 did not change. The stamped carburetor number changed from 21-1 to 21-1A.

WARRANTY:

Complete warranty claim listing:

Outboard serial number.

Qty. 2 p/n 1399-4215 Jet.

One half (0.5) hour labor.

Labor rate Code OF13.

Failure Code 705 40.



A BRUNSWICK COMPANY

W6250 W. PIONEER ROAD
P.O. BOX 1939
FOND DU LAC, WI 54936-1939 U.S.A.
PHONE (414) 929-5000 H FAX (414) 929-5060

January, 1993

Registered owner's name
and address

Dear Customer:

You are the registered owner of a model 200 Mariner or Mercury outboard motor that requires a jet change in one of the carburetors. The change involves removing the two main fuel jets from the top carburetor and installing .002 inch larger jets. The larger jets will greatly increase the durability of the engine especially when using marginal fuels. An increase in fuel consumption should NOT be noticed with the larger jets installed. All Mariner and Mercury outboard dealers were sent a service bulletin number 93-5 that describes the change.

What You Should Do:

Contact your authorized dealer, preferably the dealer that sold you the outboard. Make an appointment to have the jets replaced. Then, deliver your boat and this letter to the dealer at the appointed time. The reverse side of this letter is a pre-printed warranty that the dealer needs to send us for reimbursement.

What We Will Do:

We will reimburse the dealer for replacing the carburetor jets. You will not be charged for either parts or labor.

We apologize for inconveniencing you. We are notifying you so that you can avoid a malfunction at a future date. We thank you for your patience and understanding.

Sincerely,

A handwritten signature in black ink that reads "Bob Kachelak". The signature is written in a cursive, slightly slanted style.

Mercury Marine