

A. Water Hose Rerouting - Mariner/Mercury 50 and 60 Models

B. Anti-Fouling Paint Recommendations

C. Water Separating Fuel Filter - P/N 35-60494--1

A. WATER HOSE REROUTING - MARINER/MERCURY 50 AND 60 MODELS

Models affected:

Mariner and Mercury 50 and 60 S/N 0B396036 thru 0C134573

The water bypass hose (located on lower port side of powerhead) is susceptible of chaffing because of interference between a fastener and the side cowl. Although this is not a serious problem we want it corrected before it causes any inconvenience to the owner or operator.

The correction is to replace the 8-1/4 inch (216mm) hose with a 9 inch (229mm) hose and to reposition the rear elbow at 20°. Instructional illustrations are shown below. One hose P/N 32-75680-56 [cut to 9 inches (229mm)] and two sta-straps P/N 54-90077 are required. Labor allowance is 0.5 hour.

We shall not notify the owners to return their outboard to their dealer for this service.

We suggest this warranty service be performed whenever the outboard is returned for routine service and on all outboards (within the above serial number range) you have in your inventory. More than one outboard may be listed on a warranty claim, however it is essential that each serial number is listed.

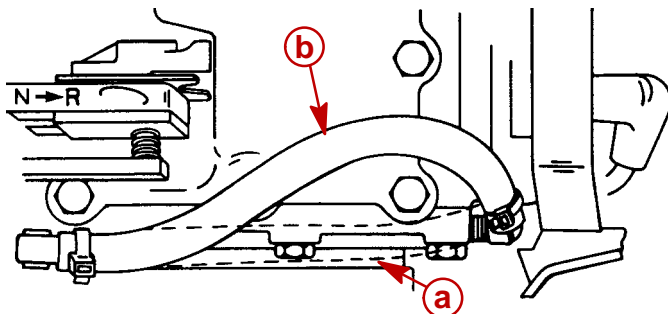
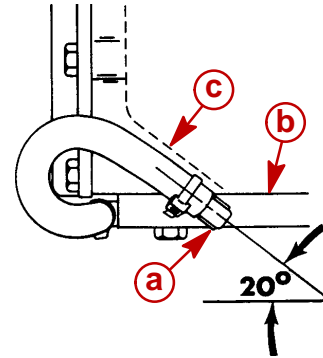

Figure 1. Side View

- a - Location of Previous Hose
- b - New Hose



50367

Figure 2. Rear View

- a - Rear Elbow
- b - Exhaust Extension Plate
- c - Rear Cowl Support Bracket

B. OUTBOARD ANTI-FOULING PAINT RECOMMENDATIONS

If anti-fouling protection is required, Tri-Butyl-Tin-Adipate (TBTA) based anti-fouling paints are recommended for below the water line housings. In areas where Tri-Butyl-Tin-Adipate based paints are prohibited by law, copper based paints can be applied to the boat hull and transom. DO NOT apply copper base paints to housings, clamp brackets, or sacrificial zinc. Corrosion damage that results from improper application of copper base paint will not be covered by the limited warranty.

C. WATER SEPARATING FUEL FILTER - P/N 35-60494--1

Previous water separating fuel filter cartridge had two rubber seals on the top cover (Figure 3). It has been determined that the outer sealing ring is not necessary for proper operation. New filter cartridges are being shipped with one (inner) sealing ring installed.

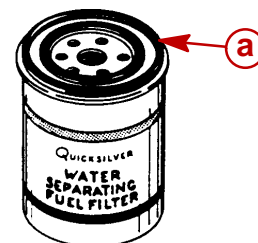

Figure 3. Fuel Filter

- a - Outer Rubber Seal