

TO: SERVICE MANAGER MECHANICS
PARTS MANAGER

No. 92-14

MCM 502 Magnum/MIE 8.2L Inboard GM Generation V Engine Specifications

NOTE: Generation V engines have the fuel pump mounted on the belt driven seawater pump.

- A. Tune-up Specifications
- B. Electrical Specifications
- C. Carburetor Specifications
- D. Internal Engine Specifications
- E. Torque Specifications
- F. Wiring Diagram (Engine)
- G. Water Flow Diagram

A. TUNE-UP SPECIFICATIONS

Model	502 Magnum	8.2L Inboard
Propshaft Horsepower (Kilowatts)	390 (292)	400 (298)
Displacement	502 CID (8.2L)	
Engine Type and Number of Cylinders	V8	
Bore	4.47 in. (113.5mm)	
Stroke	4.00 in. (101.6mm)	
Compression Ratio	8.75:1	
Compression Pressure	150 psi (1035 kPa)	
Ignition	Thunderbolt IV HEI	
Spark Plug Type	AC-MR43T or Champion RV8C	
Spark Plug Gap	.035 in. (0.9mm)	
Timing at Idle RPM	8° BTDC	
Maximum RPM at Wide- Open-Throttle	4600- 5000	4400- 4800
Idle RPM in Forward Gear	650-700	
Firing Order	1-8-4-3-6-5-7-2	
Fuel Required	87 Octane Minimum (Average Octane Rating)	
Fuel Pump Pressure	3-7 psi (21-48 kPa)	

Mode	502 Magnum	8.2L Inboard
Electrical System	12V Negative (-) Ground	
Alternator Rating	55 Amps	
Minimum Battery Rating Required	550 CCA or 120 Ah	
Crankcase Oil Capacity with New Filter*	Approx. 7 U.S. Qts. (6.6L)	
Oil Pressure at 2000 RPM	30-70 psi (207-483 kPa)	
Minimum Oil Pressure @ Idle	4 psi (28 kPa)	
Valve Lash	Not Adjustable	
Thermostat	143° F (62° C)	
Cooling System Capacity	20 U.S. Qts. (18.9L)	
Closed Cooling System Capacity	28 U.S. Qts. (26.5L)	
*Stern Drive Unit Oil Capacity (Approx.)	2.8 U.S. Qts. (2.6L)	
Transmission* (Hurth-630A) 8° Down Angle	4.2 U.S. Qts. (4.0L)	
Transmission* (Hurth- 800AM) 8° Down Angle	4.4 U.S. Qts. (4.1L)	
Transmission* (Hurth) V-drive	5.0 U.S. Qts. (4.7L)	

*Approximately, ALWAYS use dipstick to determine exact quantity of oil required.

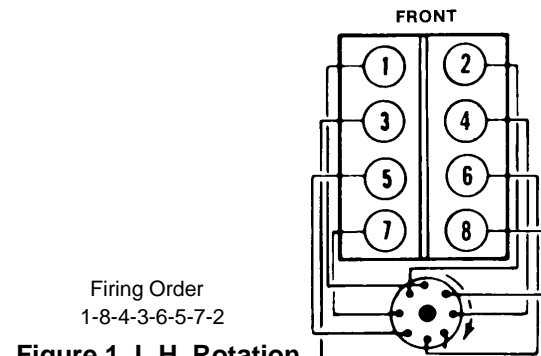

Figure 1. L.H. Rotation

B. ELECTRICAL SPECIFICATIONS

Coil Specifications

Coil	Part No. 392-7803A4
Coil Primary Resistance (Ohms) Minimum	.60
Coil Primary Resistance (Ohms) Maximum	.80
Coil Secondary Resistance (Ohms)	9.400-11.700

Starter Motor Specifications

Part Number (Delco-Remy Number)	No Load Test					Brush Spring Tension
	Volts	Min. Amps.	Max. Amps	Min. RPM	Max. RPM	
502 Magnum 50-812428A_ (9000762) 50-812604A_ (9000768)	10.6	60	90	3,000	3,300	83-104 oz. (2353-2948 g)
8.2L Inboard 50-17251A_ 50-76965A_ (10455602)	10.6	70	120	5,400	10,800	118-172 oz. (3345-4876 g)

IGNITION MODULE SPECIFICATIONS

Part Number: 817509T

Identification Mark: V8-20R

Module Advance: 20°

Initial Timing: 8° BTDC

Total Advance: 28°

Advance Curve

IMPORTANT: Advance curve chart does not include initial engine timing. Initial engine timing must be added to curve for total advance curve.

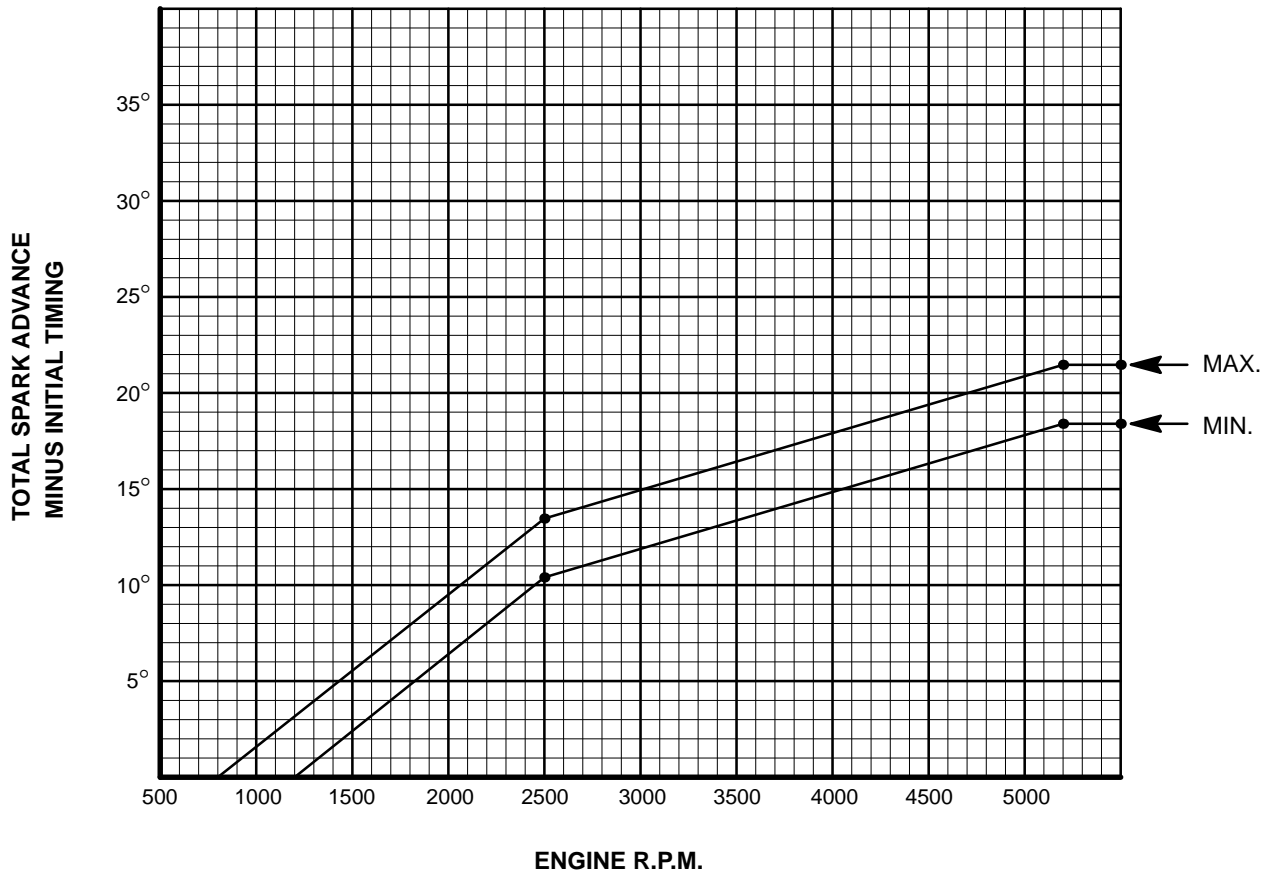

70808-14

C. CARBURETOR SPECIFICATIONS

All measurements are $\pm 1/64$ in. (0.4mm).

Model 8.2L Inboard (Early Production)

Part Number (Weber)	3310-817693A_ (9774)
Float Drop	2 in. (51mm)
Float Level	1-9/32 in. (33mm)
Pump Rod Hole Location	#3 from End
Accelerator Pump	7/16 in. (11mm) NOTE:1
Choke Pull Off	1/8 in. (3.3mm)
Choke Coil Rod	Top of Rod to be Even with Bottom of Lever Hole (NOTE:2)
Primary Jet —Throttle Lever Side —Choke Rod Side	.104 in. .107 in.
Metering Rod (Number)	16-6542
Metering Rod Step-Up Spring Color	Pink
Secondary Jet	.098 in.
Idle Mixture Screw (Preliminary)	2 Turns

NOTE 1: Accelerator pump measurement taken from flame arrestor surface to pump stem with throttle plate closed.

NOTE 2: Choke valve must be closed, choke rod in bottom of choke lever slot, and choke coil rod pushed down to end of travel.

Model MCM 502 Magnum and MIE 8.2L Inboard (Later Production)

Part Number (Weber)	3310-805341A_ (9776)
Float Drop	2 in. (51mm)
Float Level	1-9/32 in. (33mm)
Pump Rod Hole Location	#3 from End
Accelerator Pump	7/16 in. (11mm) NOTE:1
Choke Pull Off	1/8 in. (3.3mm)
Choke Coil Rod	Top of Rod to be Even with Bottom of Lever Hole (NOTE:2)
Primary Jet	.110 in.
Metering Rod (Number)	16-7147
Metering Rod Step-Up Spring Color	Pink
Secondary Jet	.101 in.
Idle Mixture Screw (Preliminary)	2 Turns

NOTE 1: Measured from Top of Carburetor to the bottom of "S" link.

NOTE 2: Remove choke rod from lever hole. Choke held closed and choke rod pushed down next to lever.

D. INTERNAL ENGINE SPECIFICATIONS

UNIT OF MEASUREMENT
in. (mm)

Cylinder Bore:

Model		502 Magnum	8.2L Inboard
Diameter		4.4655-4.4662 (113.411-113.441)	
Out of Round	Production	.001 (0.025) Max.	
	Service	.002 (0.05) Max.	
Taper	Production	Thrust Side	.005 (0.012) Max.
		Relief Side	.001 (0.025) Max.
	Service		.001 (0.02)Max.
	Clearance	Production	.0040-.0057 (0.102-0.144)
Service		.006 (0.16) Max.	

Piston Ring: (1)HI Production Limit

Compression	Groove Side Clearance	Production	Top	.0017-.0032 (0.044-0.081)
			2nd	.0017-.0032 (0.044-0.081)
		Service	(1) + .001 (0.02)	
Oil	Gap	Production	Top	.011-.021 (0.280-0.533)
			2nd	.016-.026 (0.407-0.660)
	Service		(1) + .010 (0.25)	
	Groove Side Clearance	Production	.005-.0065 (0.127-0.165)	
Service		(1) + .001 (0.02)		
Gap	Production	.010-.030 (0.254-0.762)		
	Service	(1) + .010 (0.25)		

Piston Pin:

Diameter		.9895-.9898 (25.134-25.140)
Clearance	Production	.00025-.00035 (0.007-0.008)
	Service	.001 (0.02) Max.
Fit in Rod		.0008-.0016 (0.021-0.040) Interference

Crankshaft:

Main Journal	Diameter	No. 1-5	2.7482-2.7489 (69.805-69.822)
	Taper	Production	.0002 (0.005) Max.
		Service	.001 (0.02) Max.
	Out of Round	Production	.0002 (0.005) Max.
Service		.001 (0.02) Max.	
Main Bearing Clearance	Production	No. 1-4	.0017-.0030 (0.044-0.076)
		No. 5	.0025-.0038 (0.064-0.096)
	Service	No. 1	.001-.0015 (0.03)
		No. 2 3 4	.001-.0025 (0.03-0.06)
		No. 5	.0025-.0035 (0.07-0.08)
Crankshaft End Play			.006-.010 (0.15-0.25)
Connecting Rod Journal	Diameter		2.1990-2.1996 (55.855-55.869)
	Taper	Production	.0005 (0.012) Max.
		Service	.001 (0.02) Max.
	Out of Round	Production	.0005 (0.012) Max.
Service		.001 (0.02) Max.	
Rod Bearing Clearance	Production	.0011-.0029 (0.028-0.073)	
	Service	.001-.003 (0.03-0.07)	
Rod Side Clearance			.013-.023 (0.35-0.55)
Crankshaft Runout			.0035 (0.088) Max.

@ #3 Main

Camshaft and Drive:

Model		502 Magnum	8.2L Inboard
Lobe Lift ± .002 (0.051)	Intake	.300 (7.62)	
	Exhaust	.300 (7.62)	
Duration @ .050 in. (1.27mm) Cam Lift	Intake	224°	
	Exhaust	224°	
Journal Diameter		1.9482-1.9492 (49.485-49.509)	
Journal Out-of-Round		.001 (0.02) Max.	
Camshaft Run-Out		.002 (0.05) Max.	
Timing Chain Deflection		3/8 (10mm) from Taut Position 3/4 (19mm) Total	

Valve System:

Lifter Type		Hydraulic	
Rocker Arm Ratio		1.7:1	
Valve Lash (Intake & Exhaust)		Fixed Lash	
Face Angle (Intake & Exhaust)		45°	
Seat Angle (Intake & Exhaust)		46°	
Seat Runout (Intake & Exhaust)		.002 (0.05) Max.	
Seat Width	Intake	1/32-1/16 (0.8-1.6)	
	Exhaust	1/16-3/32 (1.6-2.3)	
Stem Clearance	Production	Intake	.001-.0027 (0.026-0.068)
		Exhaust	.0012-.0029 (0.031-0.073)
	Service	Intake	.0037 (0.09)
		Exhaust	.0049 (0.12)

Valve Spring	Free Length		2.15 [2-5/32] (54.6)
	Pressure (NOTE 1)	Closed @ 1.88 [1-7/8] (47.8)	110 lbs. (489 N)
		Open @ 1.34 [1-3/8] (35.1)	316 lbs. (1406 N)
	Installed Height		1.88 [1-57/64] (47.7)
Damper	Free Length Approximate No. of Coils		1.86 [1-55/64] (47.2)
			4

NOTE 1: Test spring pressure with inner & outer spring assembled.

Cylinder Head:

Gasket Surface Flatness	.003 (0.07) in 6 (152) area .007 (0.17) Overall Max.
-------------------------	---

Flywheel:

Runout	.008 (0.203) Max.
--------	-------------------

E. TORQUE SPECIFICATIONS

Camshaft Sprocket	25 lb. ft. (34 N.m)
Conn. Rod Cap	73 lb. ft. (99 N.m)
Coupler or Drive Plate	35 lb. ft. (48 N.m)
Cylinder Head	85 lb. ft. (115 N.m)
Distributor Clamp	20 lb. ft. (27 N.m)
Exhaust Manifold (Bolts)	30 lb. ft. (41 N.m)
Flywheel	70 lb. ft. (95 N.m)
Flywheel Housing	30 lb. ft. (41 N.m)
Front Cover	120 lb. in. (14 N.m)
Intake Manifold	35 lb. ft. (48 N.m)
Main Bearing Cap	110 lb. ft. (149 N.m)
Oil Filter Adaptor Nut	40 lb. ft (54 N.m)
Oil Pan to Crankcase	200 lb. in. (23 N.m)
Oil Pan Drain Plug	15 lb. ft. (20 N.m)
Oil Pump	70 lb. ft. (95 N.m)
Oil Pump Cover	80 lb. in. (9 N.m)
Rocker Arm Bolts	45 lb. ft. (61 N.m)
Rocker Arm Cover	70 lb. in. (8 N.m)
Spark Plug	22 lb. ft. (30 N.m)
Torsional Damper	90 lb. ft. (122 N.m)
Water Pump	35 lb. ft. (48 N.m)

F. ENGINE WIRING DIAGRAM (502 MAGNUM)

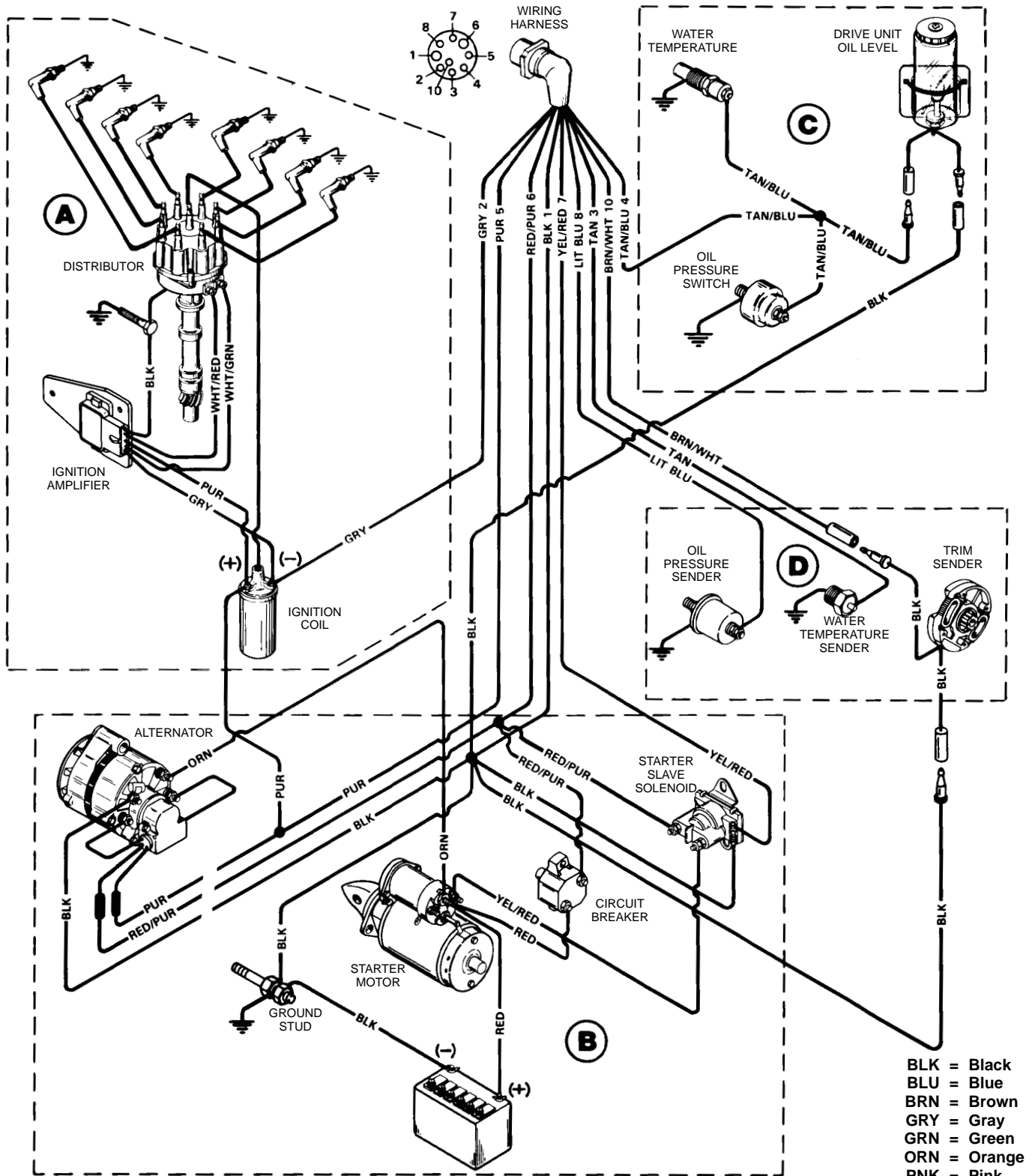

A: Ignition and Choke System
B: Starting and Charging System

C: Audio Warning System
D: Instrumentation System

F. ENGINE WIRING DIAGRAM (8.2L INBOARD)

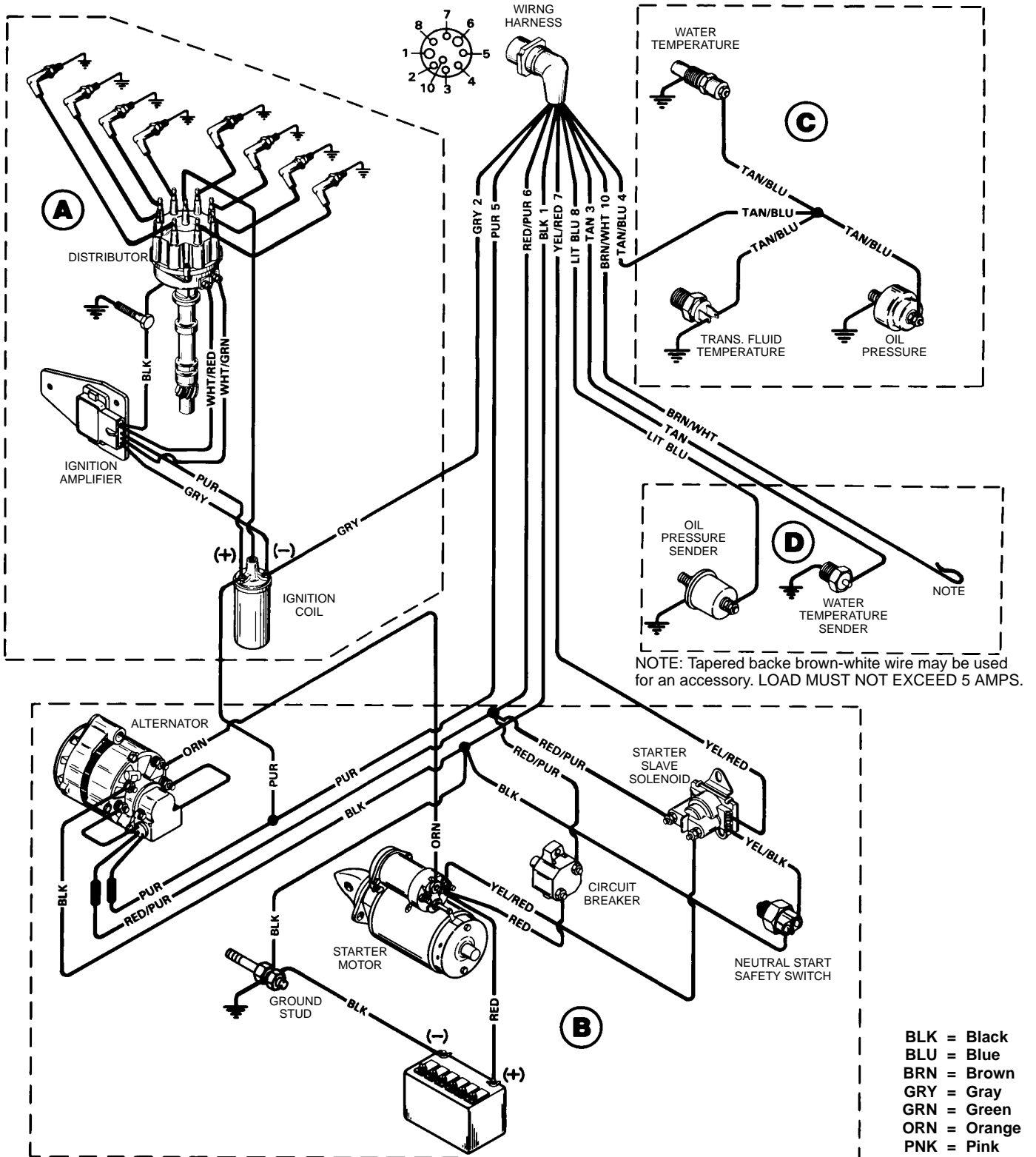

A: Ignition System
B: Starting and Charging System

C: Audio Warning System
D: Instrumentation System

- BLK = Black
- BLU = Blue
- BRN = Brown
- GRY = Gray
- GRN = Green
- ORN = Orange
- PNK = Pink
- PUR = Purple
- RED = Red
- TAN = Tan
- WHT = White
- YEL = Yellow
- LIT = Light
- DRK = Daek

G. WATER FLOW DIAGRAM (502 MAGNUM AND 8.2L INBOARD)

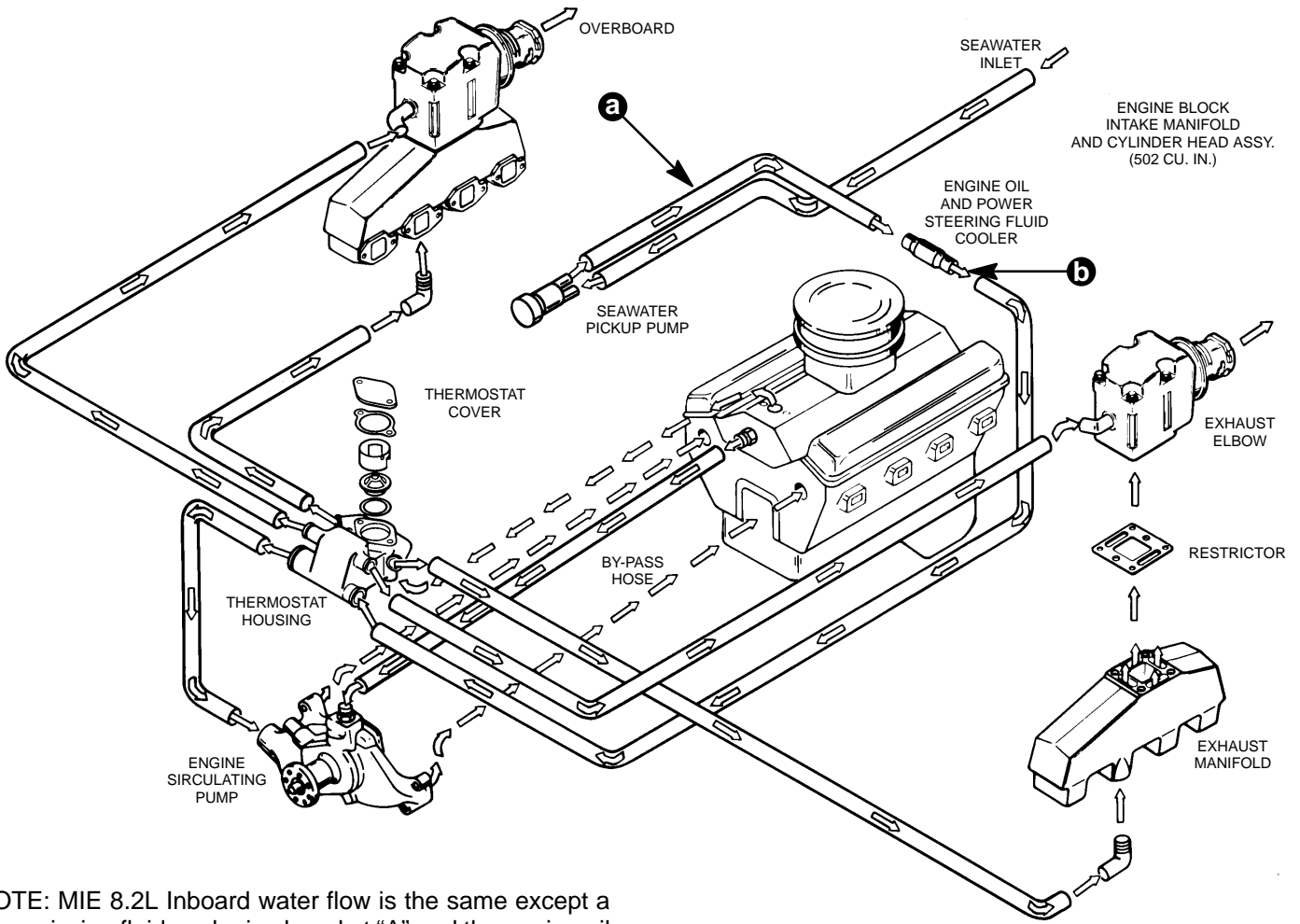

NOTE: MIE 8.2L Inboard water flow is the same except a transmission fluid cooler is placed at "A" and the engine oil cooler is placed at "B".

50702

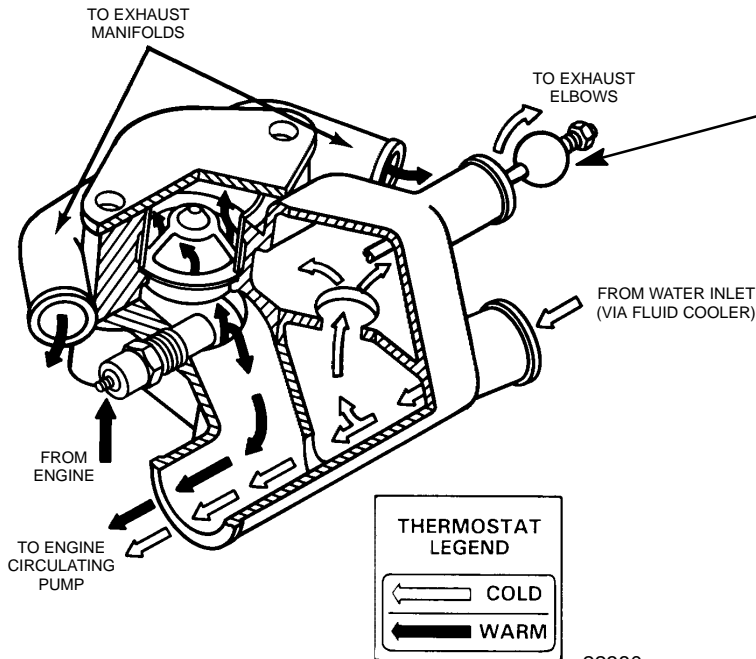

NOTE: Early production thermostat housings have poppet balls. Later production thermostat housings will not have poppet balls because of a design change inside of the thermostat housing. Water flow is the same.

22380