



# service bulletin

TO: SERVICE MANAGER  TECHNICIANS   
PARTS MANAGER

No. 94-12

Revised September, 1994

## A. EFI GASOLINE RECOMMENDATION CHANGES NUMBER 1 and 2

### Models

All 350, 454 and 502 cid EFI Stern Drive or Ski Inboard Engines

### Change Number 1

MCM 5.7L Alpha or Bravo EFI Stern Drive Engines, Serial Number 0F415136 and Below.

MCM/MIE 454 & 502 Magnum EFI Stern Drive or Ski Engines, Serial Number 0F417515 and Below.

MIE 350 Magnum EFI Ski Engines, Serial Number 0F350545 and Below.

USA and Canada: 87 (R+M)/2 Unleaded Regular Gasoline without Alcohol.

DO NOT USE Unleaded Premium or Leaded Regular Fuels.

Outside USA and Canada: 90 RON Minimum Octane Major Brand of Unleaded Regular Gasoline without Alcohol.

DO NOT USE Premium Fuel.

### Reason For Change Number 1

Use only unleaded regular gasoline in these engines. DO NOT USE premium fuel because it can and does cause certain problems such as retarding spark advance, using more fuel and setting Code 43.

Every time the engine is started, the ECM goes thru a self spark knock sensor system test when the engine reaches the specified test RPM for that particular engine. The ECM adds spark until it "hears" a spark knock. This test tells the ECM that the system is operating properly. When premium gasoline is used, the ECM may not get the engine to "knock" when it goes thru the self test. The ECM now "thinks" the knock sensor system is not operating. The ECM retards spark several degrees and adds more fuel. It will also set Code 43 because it "thinks" the knock sensor system is not working. This code will stay active during this running period.

If the fuel is switched back to unleaded regular, the ECM will do the self test the next time the engine is started and goes above its specified RPM. The engine will now run normally, however, the Code 43 will be stored in the ECM's memory. Code 43 will stay in the ECM's memory until the engine is started/stopped 100 times or until the technician clears the code.

## Change Number 2

MCM 5.7L Alpha or Bravo EFI Stern Drive Engines, Serial Number 0F415137 and Above.  
MCM/MIE 454 & 502 Magnum EFI Stern Drive or Ski Engines, Serial Number 0F417516 and Above.  
MIE 350 Magnum EFI Ski Engines, Serial Number 0F350546 and Above.

USA and Canada: 87 (R+M)/2 Unleaded Regular or Premium Gasoline Without Alcohol.  
DO NOT USE Leaded Regular Fuel.

Outside USA and Canada: 90 RON Minimum Octane Major Brand of Unleaded Regular or Premium Gasoline Without Alcohol.

## Reason For Change Number 2

The use of unleaded regular or premium gasoline in these engines is acceptable. The newest ECM used on these engines will not do the "self spark sensor system test" each time the engine is started, like the older ECM's.

These newer ECM's will still retard spark and add more fuel if it detects a spark knock during its normal operation just as the older ECM's did.

All service replacement ECM's will have this latest change in them also. The "Check-Sum" code number placed on the latest ECM's that can use either regular or premium gasoline are as follows:

350 cid EFI engines: 983E

454 cid EFI engines: 93AB

502 cid EFI engines: 939D

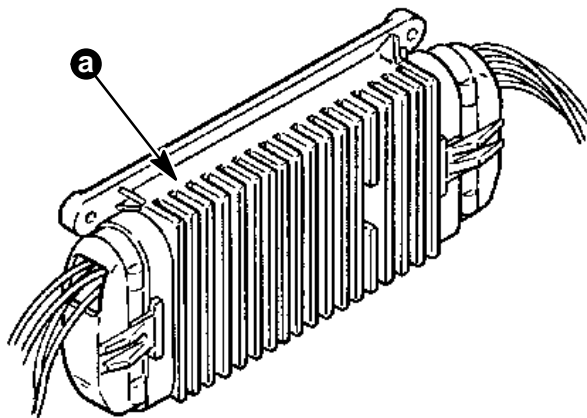

72801

a. - "Check-Sum" Code Number Location.