



MERCROISER SERVICE BULLETIN

Section: XII (Bulletins)
Number: 68-167-14
Date : 9/20/67

- A. MerCruiser Engine Alignment - 4 & 6-Cyl. (P. 9A, Sec. 11)
- B. Engine Alignment Shaft (C-91-48247) (P. 9A of Section 11)

A. MERCROISER ENGINE ALIGNMENT - 4 & 6-CYL. (For P. 9A of Installation Section 11)

Periodic inspection of engine alignment should be made on all MerCruiser 4-and-6-cylinder models with the Engine Coupler Alignment Tool (C-91-48247) to check that engine alignment has not changed because of: 1) Loose front support frame, 2) change in boat bottom (hook or rocker, 3) transom flexing or 4) unsatisfactory engine seat on mounts when installed.

Engine alignment should be checked on all MerCruiser equipped boats when performing the 20-Hour Checkup, during Spring tune-up or whenever servicing the boat to eliminate the possibility of coupler failure.

To help overcome misalignment, made at the time of engine installation, the engine height on MerCruiser 120 (Serial No. 2050045 and up) and MerCruiser 160 (2051445 and up) have been lowered $3/32''$ (2.4mm) via the narrow spacers above the engine mounts in the flywheel cover.

To lower the engine height on all MerCruiser 110, 140, 150, 60 diesel and 120's below Serial No. 2050045 and 160's below Serial No. 2051445, cut the special, double-wound spring lockwasher (B-13-33734) in half, which has the same result as installing the new spacers. (Figure 1) DO NOT CUT THE SPECIAL LOCKWASHER ON MERC 120 and 160 ENGINES ABOVE THE SERIAL NUMBERS LISTED HERE.

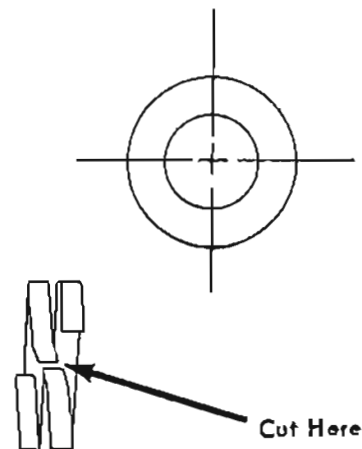

Figure 1. Cut of Special Spring Lockwasher

Engine coupling assembly failures have been caused by the following:

1. Failure of coupler splines and/or universal joint splined shaft is caused by lack of sufficient lubrication at time of installation. Remedy is to pack all couplings with Quicksilver Multi-purpose Grease (C-92-35226) or, if not available use a heavy-duty wheel bearing grease.
2. Failure of hub bond, which shears or pulls loose from the hub center, indicates engine drive misalignment because of one or more of the following:
 - a. Improper engine alignment to drive, caused by improper engine adjustment. Check alignment with Engine Coupler Alignment Shaft (C-91-48247).
 - b. Improper front engine support or support frame too weak.
 - c. Transom not to recommended thickness -- causing transom flexing.
 - d. Transom flexing caused by improper transom support.
 - e. Transom not parallel with recommended thickness.

(OVER)

B. ENGINE ALIGNMENT SHAFT ALIGNING PROCEDURE (For P. 9A of Section 11)

When using new Alignment Shaft (C-91-48247), disregard the nine (9) inch (23cm) alignment rod, which is shipped with the engine, and proceed as follows:

1. Shift engine into forward gear.
2. Remove 6 cap screws or elastic stop nuts which secure stern drive unit to bell housing and fasteners which hold Dyna-Shocks and/or trim or tilt cylinders to drive shaft housing.
3. Remove stern drive unit.
4. Check engine serial number. Modify split washer (B-13-33734) where necessary, as stated in preceding discussion (Paragraph "A"). (Figure 1)
5. Place Alignment Shaft (C-91-48247) end "A" thru gimbal bearing in gimbal housing and into engine coupler spline. (Figure 2) If alignment shaft enters coupling freely with no pressure, alignment is correct. If not, proceed as in Paragraph "6", following.
6. Loosen front mounting bracket adjusting nuts and thread either way to raise or lower front of engine until alignment shaft slides into engine coupler spline with no pressure.



Figure 2. Alignment Shaft (C-91-48247)

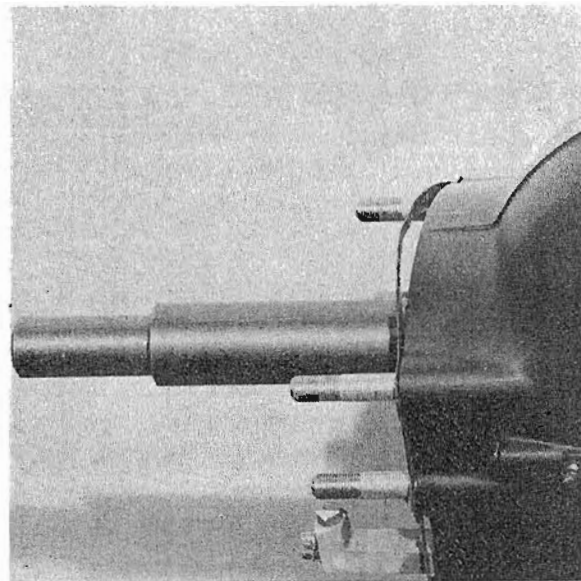

C-91-48247

Engine Alignment Shaft

\$9.75 Net U.S.

7. Tighten adjusting nuts securely after alignment is complete.
8. Place heavy coating of Multipurpose Lubricant (C-92-35226) (if not available, use a heavy-duty wheel bearing grease) on splines of coupling and universal shaft.
9. Replace stern drive unit, Dyna-Shocks, and trim or tilt cylinders, if used.

*NOTE: Engine Alignment Shaft also is used in place of C-91-37384
Bearing Alignment Shaft for aligning gimbal bearing in housing.*