

WARRANTY INFORMATION SERVICE INFORMATION

Improving Water Flow for F1, SST 120 & S2000 Racing Outboards

Models Affected: VI SSM Outboard Racing Gear Cases Serial Number R96L069 & Below

IMPORTANT: To ensure the durability of racing engines that are using VI SSM gear cases below serial number R96L070, the following recommendations should be completed.

RECOMMENDATIONS

- Upgrade water pump to the radial discharge style. Mercury Kit: P/N 849006A1
- Modify water inlet depth if not to specification. See drawing on page 2 of this bulletin.
- Use a water pressure gauge. Mercury water pressure gauge kit: P/N 79-825331A1

The radial discharge water pump with its improved water flow characteristics is recommended for VI SSM racing gear cases serial number R96L069 and below. Installation instructions are included with the kit but note that the exhaust plate has to be machined for the 3/4" (19mm) water tube (dimensions are in the kit instructions).

The water inlet on the gear case also needs to be checked for proper depth. Older gear cases that are not machined to specification could limit the water flow to the powerhead. The angle of the top of the water inlet should be maintained at 2° from vertical.

A water pressure gauge is important when doing set-up changes since the height of the engine can make significant changes in the water supply. Connect gauge at the 1/8" brass pipe plug location on the exhaust cover above the ignition coils.

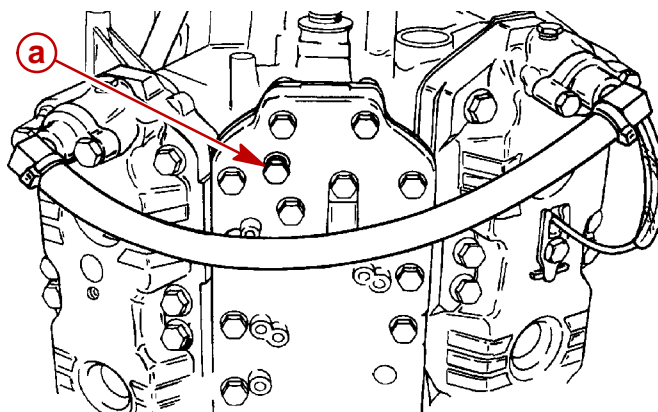

a - Brass Pipe Plug

Minimum Water Pressure: 14 psi for half of each race straight away

WATER INLET INSPECTION

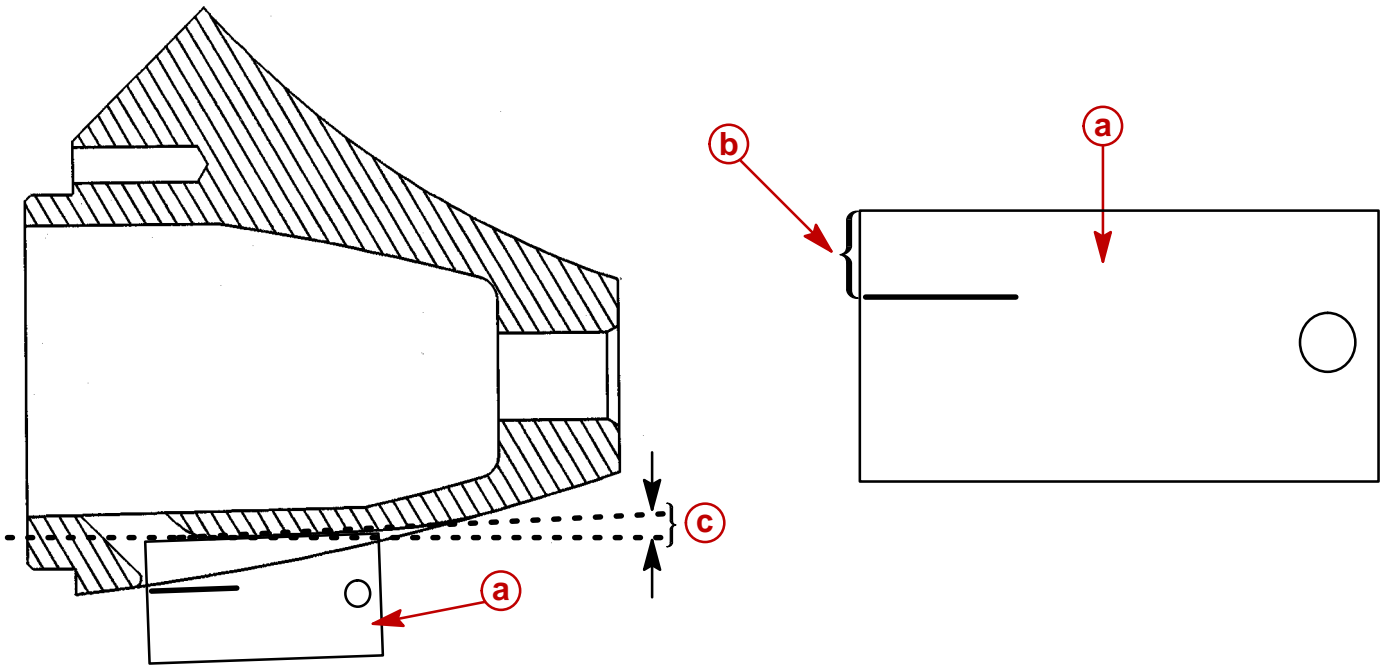

- a** - Fabricated Metal Depth Gauge
- b** - Depth Line on Gauge 0.230-0.250 in (5.8-6.35 mm) with 2° inlet angle
- c** - 2° inlet angle must be maintained.