



# service bulletin

No. 96-4

## Official Recall Notification Federal Boat Safety Act Commander 3000 Remote Control

### Commander 3000 Remote Controls

88150A40	88150A41	88150H41
88150A42	88150A43	88150A44
88150A45	88150A47	88150A48
88150A50	88150A51	827270A1
827270A2	827270A3	827270A5
827270A6	827270A7	827270A8
827270A9	827270A10	827270A11
88688A40	88688A42	88688H42
88688A44	88688A46	88688A48
88688A50	88688A51	88688A52
88688H52	88688A54	88688A56
88688A57	88688A58	

Commander 3000 remote controls built between June 1, 1994 and September 1, 1995 could fail and result in the inability to reduce throttle and shift the engine out of gear. Failure is caused by an improperly hardened gear in the control mechanism.

### REWORK IDENTIFICATION:

Commander 3000 remote controls built between June 1, 1994 and September 1, 1995 that have been reworked at the factory have a decal with the letters RKFV on the control. The affected gear has been replaced on these controls and the control is approved for use.

### OWNER NOTIFICATION (US AND CANADA):

A combination letter/claim will be sent to every registered owner of an engine on a boat built from June 1, 1994 through September 30, 1995 that may have used these Commander 3000 controls. The hull identification number (HIN) of these boats will end in the 4 digits F4XX through I5XX. The letter will advise the owner to determine if their control is included in this recall, and to make an appointment with an authorized dealer to have affected controls inspected and replaced if necessary. A copy of the letter/claim is included with this service bulletin.

### DEALER AND BOAT BUILDER PARTS STOCK:

Inspect all Commander 3000 controls in parts stock. Return all controls with a build date on the mechanism between June 1, 1994 and September 1, 1995 that do not have the RKFV rework decal. Return all controls found with no build date. See the identification sheet for an explanation of the various dating methods used.

Boat Builders are asked to report the quantity and destination or registered owners of boats that may have been built with affected Commander 3000 controls and engines from other manufacturers. Please fax the information to Commander 3000 Recall 1-800-842-4550.

**Dealers and Boat Builders can use the following numbers to obtain information on this recall. In the USA: fax 1-800-842-4550 or call 1-800-309-4743. In Canada: fax 1-800-663-8334 or call 1-905-270-4481, extension 259.**

### BOAT BUILDER BOAT INVENTORY:

Inspect all boats in inventory that **may have** Commander 3000 controls built between June 1, 1994 and September 1, 1995. Replace and return all controls with a build date on the mechanism between June 1, 1994 and September 1, 1995 that do not have the RKFV decal. Return all controls found with no build date. Commander 3000 controls may have been installed on boats built with engines from other manufacturers. These controls also require inspection.

## DEALER BOAT INVENTORY:

Inspect Commander 3000 controls on unsold boats in inventory. Commander 3000 controls are most likely to appear on boats with HIN numbers ending in F4XX through I5XX. Replace and return all controls with a build date on the mechanism between June 1, 1994 and September 1, 1995 that do not have the RKFV decal. Return all controls found with no build date. Commander 3000 controls may be used with engines from other manufacturers.

## DEALER SALES OF COMMANDER 3000 CONTROLS:

Dealers are asked to contact purchasers of Commander 3000 controls, if possible, to bring their boat in for inspection. Inspect, replace and return all controls with a build date on the mechanism between June 1, 1994 and September 1, 1995 that do not have the RKFV decal. Return all controls found with no build date.

## CORRECTION:

1. The mechanism of Commander 3000 remote controls built between June 1, 1994 and September 1, 1995 that do not have the RKFV decal, and those found with no build date must be replaced. The control handle, bezel and cover are to be re-used.
2. Install per the instructions enclosed with the mechanism. Video tape, p/n 90-823732-43, Control Box and Cable Adjustment, will be mailed to all US and Canada dealers, under separate cover, to assist with the replacement.
3. Readjust the throttle and shift cables and control throttle friction carefully per the applicable service manual.

## PARTS REQUIRED:

1. Order p/n 852430A 1 for panel mount controls.
2. Order p/n 852430A 2 for console mount controls.

## WARRANTY:

Complete a warranty claim listing:

- Engine serial number if the control is in a boat, or Part number of controls from stock.
- Quantity ( ) 852430A 1 Panel Mount Mechanism, or  
Quantity ( ) 852430A 2 Console Mount Mechanism, or  
Quantity ( ) and part number of controls from stock.
- One-half hour (0.5) labor to inspect controls in boats.  
One and three tenths hour (1.3) labor to inspect and replace controls in boats.  
One quarter hour (0.25) labor to inspect and return controls from stock.
- Labor Rate Code: OR19 for inspection only, OR20 for inspection and replacement.
- Failure Code: 318 40

USA and Canada: Control mechanisms **must be returned** along with the preprinted paper warranty claim from that was sent to the customer. Return individual mechanisms with the UPS pick-up tag packed with the new mechanism. Return complete controls with a paper warranty claim form. Return large quantities of controls and mechanisms freight collect.

International: Hold controls and control mechanisms for inspection/disposal by a Mercury Marine International Technical Representative.

## NOTICE OF RECALL UNDER THE FEDERAL BOAT SAFETY ACT

Dear Mercury Marine Customer:

Our records indicate that your boat **may** be equipped with a Commander 3000 shift/throttle control, which may be included in a Federal Boat Safety Act recall. Quicksilver Commander 3000 control units built between June 1, 1994 and September 1, 1995 could fail and result in the inability to reduce throttle and shift the engine out of gear.

### WHAT YOU SHOULD DO

1. Determine if you have a Commander 3000 control in your boat using the enclosed identification sheet. If you do not have a Commander 3000 control, this recall does not apply to you. In that case, please proceed directly to number 5. If you do have a Commander 3000 control, please continue reading.
2. Determine if your Commander 3000 control is included in this recall. View the decals on the control mechanism per the enclosed identification sheet.

**You are affected by this recall, and the control mechanism must be replaced, if it was built between June 1, 1994 and September 1, 1995 and it does not have a "RKFV" decal on it.** The RKFV decal indicates that the control was corrected at the factory.

**You may be affected by this recall, and dealer inspection is required, if the build date is not visible, is not readable or is missing.**

3. Make an appointment with a dealer authorized to service your Mercury, Mariner, MerCruiser or Force product if your control mechanism must be replaced or inspected.
4. Deliver your boat **and this letter** to your dealer at the appointed time.
5. If you are not affected by this recall, or if you have sold or traded the boat, please complete the lower portion of the form printed on the reverse side of this letter and return the complete letter to us in the envelope provided.

### WHAT WE WILL DO

We will reimburse the authorized dealer for inspecting and / or replacing the control mechanism as necessary. Your throttle/shift handle and bezel will be reused. You will not be charged for this procedure.

### WARNING

**Since failure can occur without warning, Mercury recommends against use of your boat until your Commander 3000 mechanism has been inspected and / or replaced. If you choose to operate your boat before inspection and replacement is completed, and failure occurs, you will be able to stop the boat only by turning off the ignition switch or by pulling the safety switch lanyard. You will not be able to restart the engine because the throttle/shift lever cannot be returned to the neutral starting position.**

Mercury Marine apologizes for this inconvenience. We have taken this action in the interest of customer satisfaction and safety. If you have any questions, or need help locating an authorized dealer, please call 800-309-4743 or, in Canada, call 905-270-4481, extension 259 with this letter in hand.

Sincerely,

Larry Engelbert

Bob Kachelek

Fred Wolf

MerCruiser Service - USA

Outboard Service - USA

Service - Canada



# WARRANTY CLAIM

A BRUNSWICK COMPANY

MERCURY MARINER MERCUISER FORCE QUICKSILVER

NOTIFY DATE

ENGINE SERIAL NUMBER

CUSTOMER NAME		DEALER NAME	
ADDRESS		DEALER CODE	
CITY, STATE, ZIP		DEALER ADDRESS	
MODEL / SERIAL NUMBER		CITY, STATE, ZIP	
DATE OF SALE	ORDER NUMBER	LABOR RATE	
DESCRIPTION OF FAILURE <b>COMMANDER 3000 REMOTE CONTROL RECALL</b>			
FAIL CODE <b>318</b>	FAILURE CODE DESCRIPTION <b>40</b>	NOTE: WARRANTY CLAIM MUST BE RECEIVED WITHIN 30 DAYS OF REPAIR DATE TO BE CONSIDERED FOR APPROVAL.	PRE-AUTH NUMBER
		ENTER DATE	

PRODUCT (CHECK ONE ONLY) <input type="checkbox"/> OUTBOARD <input type="checkbox"/> STERNDRIVE <input type="checkbox"/> INBOARD <input type="checkbox"/> INFLATABLES <input type="checkbox"/> JET <input type="checkbox"/> QUICKSILVER P&A <input type="checkbox"/> OTHER - SPECIFY _____		DATE FAILED  DATE REPORTED  DATE REPAIRED  HOURS USED
--	--	---

REPAIR PARTS IDENTIFICATION						LABOR PERFORMED PER FLAT RATE MANUAL			
QTY	PART NUMBER	PART DESCRIPTION	RETURN	LIST PRICE	TOTAL	CODE	DESCRIPTION	HRS	DOLLARS
							TOTAL LABOR		
							TOTAL PARTS		
							SUB TOTAL		
							TAX		
							SUBLET LABOR (RECEIPT ATTACHED)		
							FREIGHT (ATTACH RECEIPT IF OVER \$10.00)		
							<b>GRAND TOTAL</b>		

### CUSTOMER TO COMPLETE THIS SECTION

I have viewed the shift/throttle control in my boat and it:

- Does not match any of the Commander 3000 controls pictured on the identification sheet.
- Does match one of the controls pictured but the build date is not between June 1, 1994 and September 1, 1995.
- Does match one of the Commander 3000 controls pictured and the build date is between June 1, 1994 and September 1, 1995 and has the RKFV decal.
- The boat was sold or traded to: \_\_\_\_\_  
address: \_\_\_\_\_  
city/state/zip: \_\_\_\_\_

**RETURN TO MERCURY MARINE IN THE ENVELOPE PROVIDED**

# COMMANDER 3000 CONTROL IDENTIFICATION SHEET

1. **Determine if you have a Commander 3000 control.** If the control in your boat does not match any of the controls pictured below you do not have a Commander 3000 control and this recall does not apply to you.

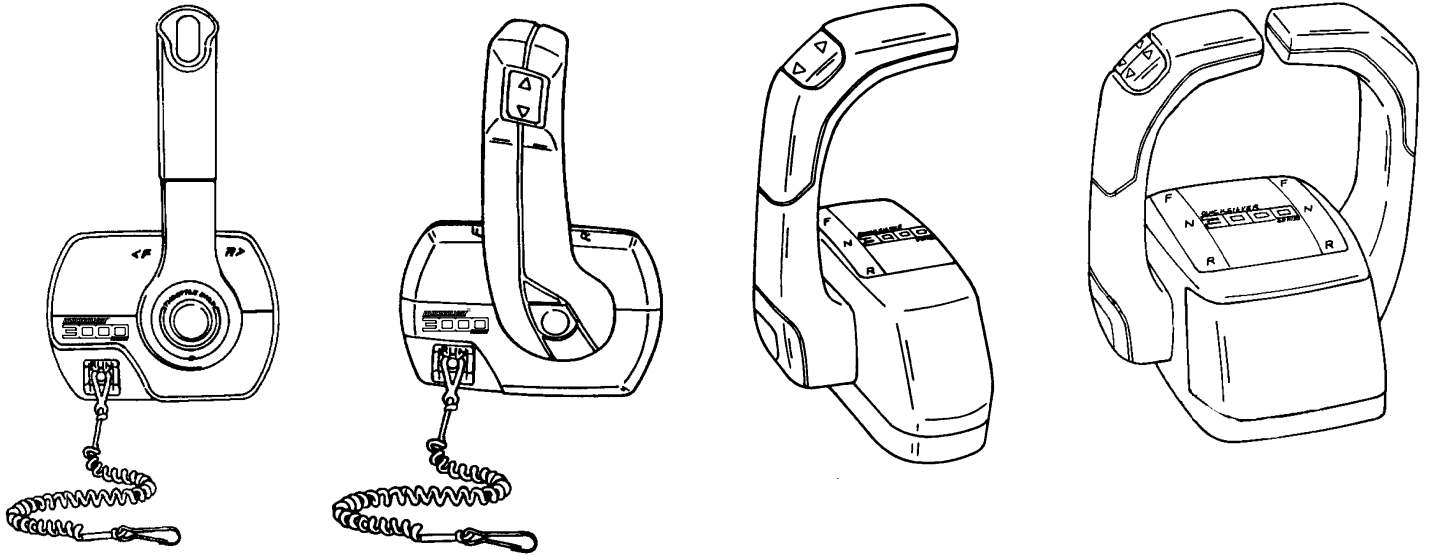

2. **Determine if your Commander 3000 control is included in this recall.** View the decals on the control, if visually accessible, in the location shown below. Use a flashlight and mirror to help read the decals.

**You are affected by this recall, and the control mechanism must be replaced, if it was built between June 1, 1994 and September 1, 1995 and does not have a "RKFW" decal on it.**

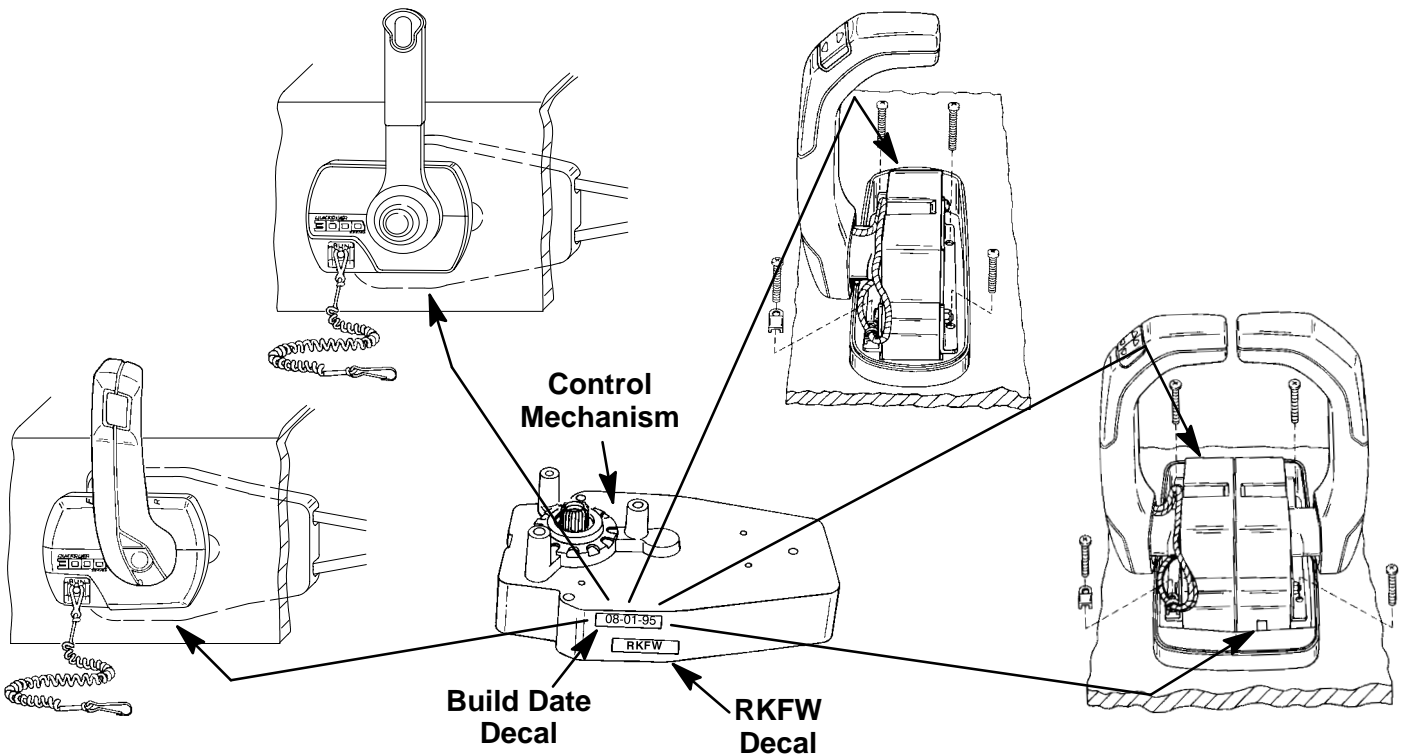

**NOTE:** The date may appear on the control in different forms: 08/01/95 (month/day/year) August 1, 1996. The month may also be written out in alpha characters as in the following: Aug/1/95 or 1/Aug/95. Decals may be placed in other locations.