



service information

ADVISORY
 BULLETIN

No. 2000-14
(Mercury Jet Drives No. 2000-02)

Circulate to: Sales Manager Accounting Service Manager Technician Parts Manager

Hard Starting - 240 EFI M² Jet Drive

Models Affected:

240 EFI M² Jet Drive

Serial number - 0E249035 thru 0E386118

If you encounter hard starting on one of the units identified above, please follow the procedure below.

Before proceeding, there are some items to check.

- Check spark plug condition because the procedures for mixing the oil with the gasoline for break-in may not have been done properly.
- Check to ensure that the proper spark plugs are used (NGK BPZ8HS-10). Mercury has found that incorrect spark plugs can exhibit the same hard starting symptoms.
- The throttle shutter must be completely closed for prompt starting of the Jet Drive. The following are conditions that could cause the throttle shutter to be open.
 1. Be aware that the low speed control retainer on the powerhead could prevent the throttle shutter from completely closing. Please verify this first.
 2. Check to ensure that the steering wheel is not bottomed in either direction. This could activate the low speed control that opens the throttle shutter.
 3. Check to ensure that the throttle cable is connected to the proper hole in the remote control. If connected to the incorrect hole, the throttle travel may not be sufficient to completely close the throttle shutter.

- Disconnect the TAN/BLACK lead wire from the temperature sensor and then start the engine. If this resolves the hard start condition, follow the corrective action described below.

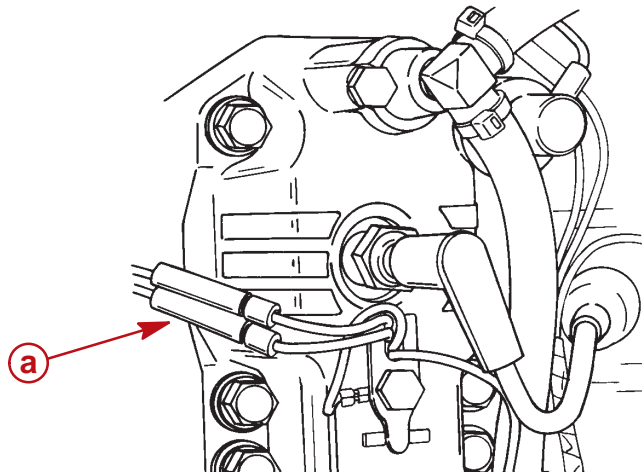

a - Disconnect TAN/BLACK Leads

Correction

- Connect the DDT tester (91-823686A2) with cartridge (91-822608-6) to engine using the adapter cable (84-822560A5). Refer to DDT Tech manual (90-825159-2) for detailed instructions (p. 52).

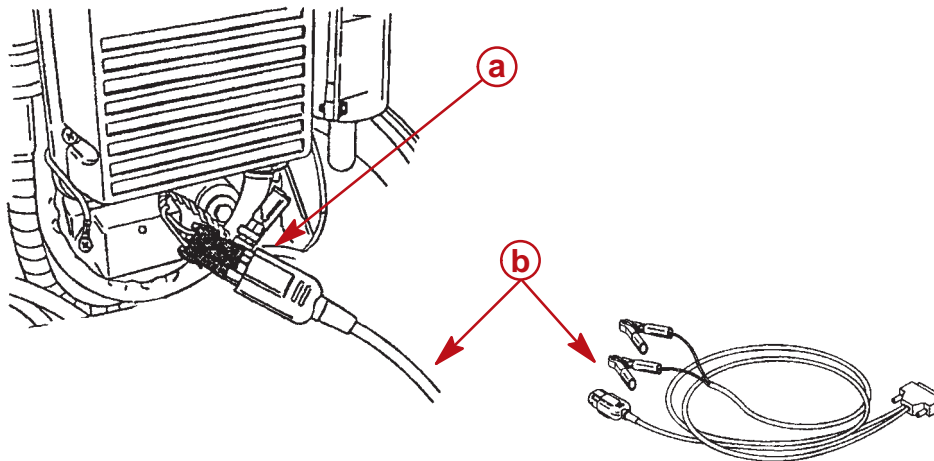

a - ECM Diagnostic Port

b - DDT Adaptor Cable

- Turn ignition switch to the “ON” position. Turn DDT on. Check the PROM ID. It should read “**EC67**”. If it does not, contact Mercury Technical Service.
- Check TPS. It should be between .20 and .30 at idle speed. Readjust as necessary.
- With jet unit in water, first loosen locknut on idle timing screw. Start the engine and allow enough time to thoroughly warm up (at least 5 minutes).

NOTE: This procedure **CANNOT** be performed with unit out of the water using the flushing adapter. The engine needs the load of the water being drawn in through the impeller.

- With the DDT attached and engine idling: Hold throttle arm against idle stop (throttle cable barrel removed from barrel retainer). Adjust idle timing screw to 10 degrees BTDC. Tighten locknut.

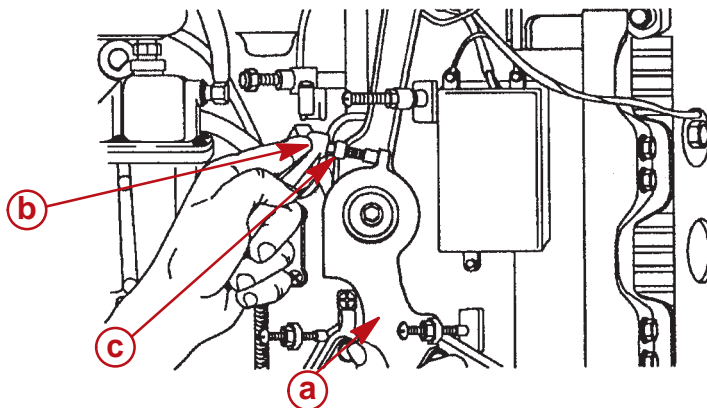

- a - Throttle Arm
- b - Idle Timing Screw
- c - Locknut

- Adjust idle speed screw by turning idle speed screw counterclockwise until the rpm drops below 950. Then turn the screw clockwise to increase the speed to 1050 rpm.

NOTE: It is important to drop the rpm below 950 and then increase it to 1050. Also note that the idle speed screw is difficult to access. It is between the ECM and the vapor separator tank.

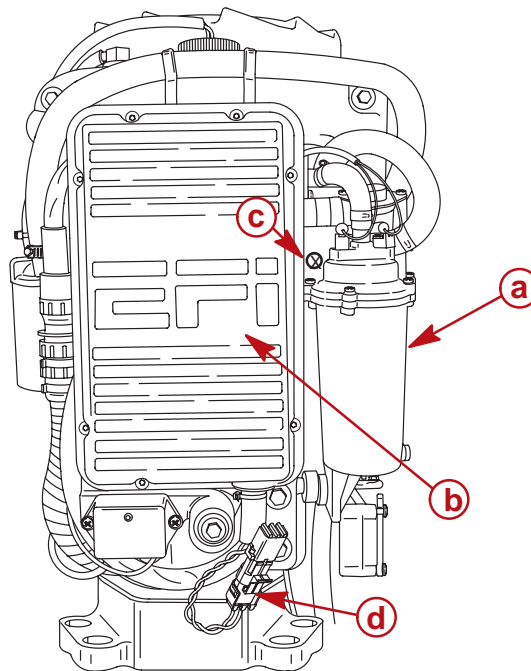

- a - Vapor Separator
- b - ECM
- c - Idle Speed Screw
- d - ECM Diagnostic Port

58152

- To locate the idle speed screw, placing a mirror in front of the vapor separator tank will definitely help. A tool was found to help guide as well as align the screw driver tip to the slots on the idle speed screw. It has a sleeve that slides over the screw driver tip. It can be purchased at any hardware, home center, or Sears stores. The tool is located in the area of the cordless drills/drivers. **Skil** calls the tool a Starter/Driver (part number - 43955). The **Sears** tool is a Craftsman Screw Guide (part number - ⁹ 26200).

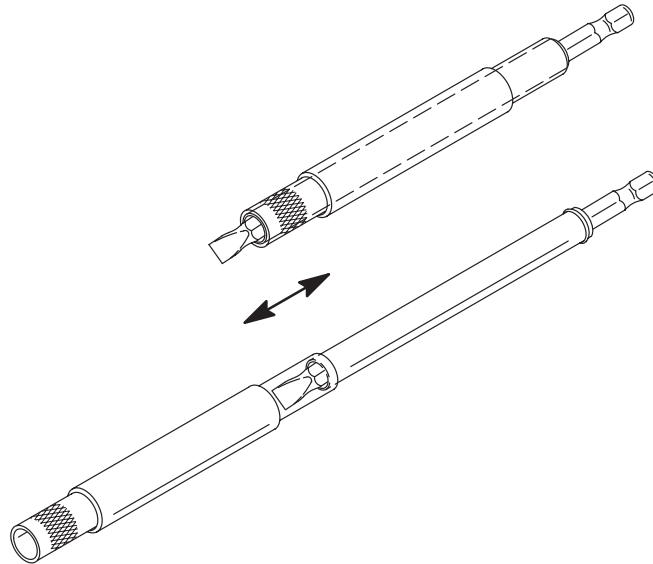

58736

- To use the tool is simple. Push the sleeve over and past the screw driver tip by at least an inch. Locate the Idle speed screw using a mirror. Insert the tool over the idle speed screw head. Push on the screw driver portion of the tool until the tip contacts the screw head. Slowly rotate the screw driver until the tip engages the slot in the screw

Warranty

Mercury Marine will credit the dealer for the cost of labor for one year from the issuance of this advisory. Please note the month and year located at the lower left corner of the front page of the advisory.

Complete warranty claim listing:

- Powerhead serial number(s)
- One (1.0) hour labor
- Warranty Flat Rate Code: NJC
- Part Code: 799
- Failure Code: OO

US and Canada: Complete/process claim via Midas or return warranty claim form.

INTERNATIONAL: Follow instructions issued by Marine Power International office or by your distributor.