

TO: SERVICE MANAGER MECHANICS
PARTS MANAGER

REVISED
11-14-94

No. 93-5

H.P. 500 (502 cid) Specifications

- A. Tune-up Specifications
- B. Electrical Specifications
- C. Carburetor Specifications
- D. Internal Engine Specifications
- E. Torque Specifications
- F. Wiring Diagram
- G. Water Flow Chart

A. TUNE-UP SPECIFICATIONS

Horsepower (Kilowatts)	500 (373)
Displacement (Liters)	502 CID (8.2)
Engine Type and Number of Cylinders	V-8
Bore	4.468 in. (113.48 mm)
Stroke	4.00 in. (101.6mm)
Compression Ratio	8.75:1
Compression Pressure	175 psi (1207 kPa)
Ignition	Thunderbolt IV
Spark Plug Type	AC-MR43T, NGK BR6FS, or Champion RV8C
Spark Plug Gap	.035 in. (0.9mm)
Timing at Idle RPM (Note)	14° BTDC
Maximum Advance @ 3200 RPM	34° BTDC
Maximum RPM at Wide-Open-Throttle	4800-5200
Idle RPM in Forward Gear	700-750
Firing Order	1-8-4-3-6-5-7-2
Fuel Required	87 Octane $\{(R+M)\div 2\}$ or 92 RON
Fuel Pump Pressure	3-7 psi (10-48 kPa)

NOTE: Timing should be checked at 3200 RPM. At this RPM, timing should be 34° BTDC. Adjust initial timing to achieve 34° at 3200 RPM.

Electrical System	12-Volt Negative Ground
Alternator Rating	55 Amperes
Recommended Battery Rating	Min. 550 Amps Cold Cranking Amperage
Crankcase Oil Capacity with New Filter*	8 Qts. (7.5Liters)
Oil Pressure at 2000 RPM	30-70 psi (207-483 kPa)
Thermostat	143° F (62° C)
Cooling System Capacity	20 U.S. Qts. (18.9L)
Stern Drive Unit Oil Capacity With Monitor (Approx.)	Bravo: 2.8 U.S. Qts. (2.7L)

*Approximately, ALWAYS use dipstick to determine exact quantity of oil required.

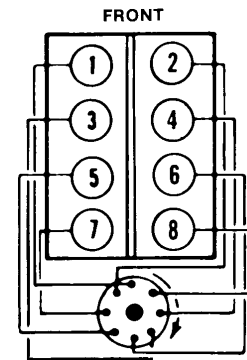

Firing Order
1-8-4-3-6-5-7-2

Figure 1. L.H. Rotation

B. ELECTRICAL SPECIFICATIONS

Ignition Specifications

Timing	34° BTDC @ 3200 RPM
Coil	Part No. 392-805570A2
Coil Primary Resistance (Ohms) Minimum	.60
Coil Primary Resistance (Ohms) Maximum	.80
Coil Secondary Resistance (Ohms)	9.4-11.7

Starter Motor Specifications

Mercury Marine Part Number	50-99418A-2			
Delco Remy Part Number	10455603			
Brush Spring Tension	56-105 OZ (1588-2976 g)			
No Load Test				
Volts	Amps. (Min.)	Amps. (Max.)	RPM (Min.)	RPM (max.)
10.6	70	120	5400	10,800

C. CARBURETOR SPECIFICATIONS

All measurements are $\pm 1/64$ in. (0.4mm).

Make (Model)	Holley (4150)
Part No. Mercury (Holley)	13549A12 (80466)
Float Adjustment	Bottom of Sight Plug Hole $\pm 1/32$ " (.8 mm)
Primary Jets	PORT: No. 81 STBD: No. 75
Secondary Jets	PORT: No. 89 STBD: No. 93
Accelerator Pump	.015" (.4 mm)
Choke Setting	Index Marks Aligned
Idle Mixture Screw Preliminary Setting	1/2 to 1 turn

D. INTERNAL ENGINE SPECIFICATIONS

**UNIT OF MEASUREMENT
in. (mm)**

Cylinder Bore:

Diameter		4.4662-4.4655 (113.442-113.424)	
Out of Round	Production	.001 (0.025) Max.	
	Service	.002 (0.05) Max.	
Taper	Production	Thrust Side	.0005 (0.0127) Max.
		Relief Side	.001 (0.025) Max.
	Service	.001 (0.025)Max.	

Piston: See Note

Clearance	Production & Service	.004-.006 (0.102-0.152)
-----------	----------------------	-------------------------

NOTE: Measure piston at wrist pin centerline and 90° from piston pin.

Piston Ring: (1)HI Production Limit

Compression	Groove Side Clearance	Production	Top	.0017-.0032 (0.0432-0.0812)
			2nd	.0017-.0032 (0.0432-0.0812)
		Service	.001 (0.02) over hi production limit	
	Gap	Production	Top	.022-.024 (0.558-0.610)
			2nd	.020-.022 (0.508-0.558)
		Service	.010 (0.254) over hi production limit	
Oil	Groove Side Clearance	Production	.0025-.0045 (0.0635-0.1143)	
		Service	.006 (0.152) Max.	
	Gap	Production	.015-.055 (0.381-1.397)	
		Service	.015-.055 (0.381-1.397)	

Piston Pin:

Diameter		.9895-.9898 (0.0251)
Clearance to piston	Production	.00025-.00035 (0.0064-0.0089)
	Service	.0012 (0.030) Max.
Fit in Rod		.0008-.0016 (0.0203-0.0406) Interference

Crankshaft:

Main Journal	Diameter	No.1,2,3,4,5	2.7482-2.7489 (69.805-69.822)
	Taper & Out of Round	Production	0005 (0.0127) Max.
Service		.001 (0.025) Max	
Main Bearing Clearance	Production	No.1,2,3,4	.0013-.0025 (0.0330-0.064)
		No. 5	.0024-.0040 (0.0610-0.1016)
	Service	No.1,2,3,4	.0010-.0025 (0.025-0.0635)
		No. 5	.0025-.0040 (0.0635-0.1016)
Crankshaft End Play			.006-.010 (0.152-0.254)
Connecting Rod Journal	Diameter		2.1990-2.2000 (55.855-55.880)
	Taper & Out of Round	Production	.0005 (0.0127) Max.
		Service	.001 (0.025) Max.
Rod Bearing Clearance	Production	.0009-.0025 (0.0229-0.0635)	
	Service	.0009-.0030 (0.0229-0.0762) Max.	
Rod Side Clearance			.013-.023 (0.330-0.584)
Crankshaft Runout			.005 (0.125) Max.

Camshaft and Drive:

Lobe Lift ± .002 (0.051 mm)	Intake	.339 (8.61)
	Exhaust	.352 (8.94)
Journal Diameter	1.948-1.949 (49.48-49.51)	
Journal Out-of-Round	.0005-.001 (.013-.025)	
Camshaft Run-Out	.0005-.001 (.013-.025)	
Timing Chain Deflection	.500 (12.7)	
Camshaft End Play	.006-.013 (.15-.33)	

Valve System:

Lifter Type	Hydraulic Roller		
Rocker Arm Ratio	1.7:1		
Valve Lash (Intake & Exhaust)	3/4 Turn Down from Zero Lash		
Face Angle (Intake & Exhaust)	45°		
Seat Angle (Intake & Exhaust)	45°		
Seat Runout (Intake & Exhaust)	.002 (0.050) max.		
Seat Width	Intake	.040-.060 (1.02-1.52)	
	Exhaust	.060-.090 (1.52-2.29)	
Stem Clearance	Production	Intake	.0010-.0025 (0.025-0.064)
		Exhaust	.0012-.0025 (0.030-0.064)
	Service	Intake	.0010-.003 (0.025-0.076)
		Exhaust	.0010-.003 (0.025-0.076)
Valve Spring	Free Length		2.320 (58.93)
	Pressure Lbs. @ In (NOTE)	Closed @ 1.900 (47.6)	150 lb. (667 N)
		Open @ 1.302 (33.1)	420 lb. (1868 N)
	Installed Height		1.900 (48.3)

NOTE: Test springs as a complete assembly with retainer.

Cylinder Head:

Gasket Surface Flatness	.006 (0.152) Overall Max. .003 (0.076) within a 6 in. (152 mm) span
-------------------------	---

Flywheel:

Runout	.008 (0.203) Max. (Face Area)
--------	----------------------------------

E. TORQUE SPECIFICATIONS

Camshaft Sprocket/Gear (NOTE 1)	25 lb.ft. (34 N·m)
Conn. Rod Cap (NOTE 2)	65 lb. ft. (88 N·m)
Crankcase Front Cover	80 lb. in. (9 N·m)
Cylinder Head (NOTE 3)	Step #1-20 lb.ft. (27 Nm.) Step #2-50 lb.ft. (68 Nm.) Step #3-75 lb. ft. (102 N·m)
Distributor Clamp	15 lb. ft. (20 N·m)
Exhaust Manifold (Bolts)	30 lb. ft. (41 N·m)
Flywheel (NOTE 1)	70 lb. ft. (95 N·m)
Flywheel Drive Plate (NOTE 1)	35 lb. ft. (48 N·m)
Flywheel Housing	30 lb. ft. (41 N·m)
Intake Manifold	30 lb. ft. (41 N·m)
Main Bearing Cap	110 lb. ft. (149 N·m)
Oil Pan to Crankcase (5/16-18)	165 lb. in. (19 N·m)
Oil Pan to Crankcase (1/4-20)	80 lb. in. (9 N·m)
Oil Pan Drain Plug	20 lb. ft. (27 N·m)
Oil Pump (NOTE 1)	70 lb. ft. (95 N·m)
Oil Pump Cover (NOTE 1)	80 lb. in. (9 N·m)
Rocker Arm Stud (NOTE 1)	45 lb. ft. (61 N·m)
Rocker Arm Cover	72 lb. in. (8.1 N·m)
Spark Plug	15 lb. ft. (20 N·m)
Torsional Damper	85 lb. ft. (116 N·m)
Water Pump	30 lb. ft. (41 N·m)
Cam Thrust Plate (NOTE 1)	70 lb.in. (8 N·m)

NOTE 1: Use Loctite 271 (P/N 92-32609-1) on threads.

NOTE 2: Apply engine oil to stud threads and contacting surface of nut.

NOTE 3: Apply moly lube under bolt head, and teflon pipe thread sealant (like Loctite sealant #592) on threads.

NOTE 4: Use only Mercury gasket P/N 27-818188.

F. ENGINE WIRING DIAGRAM - HP500 (502 CID) (THUNDERBOLT IGNITION)

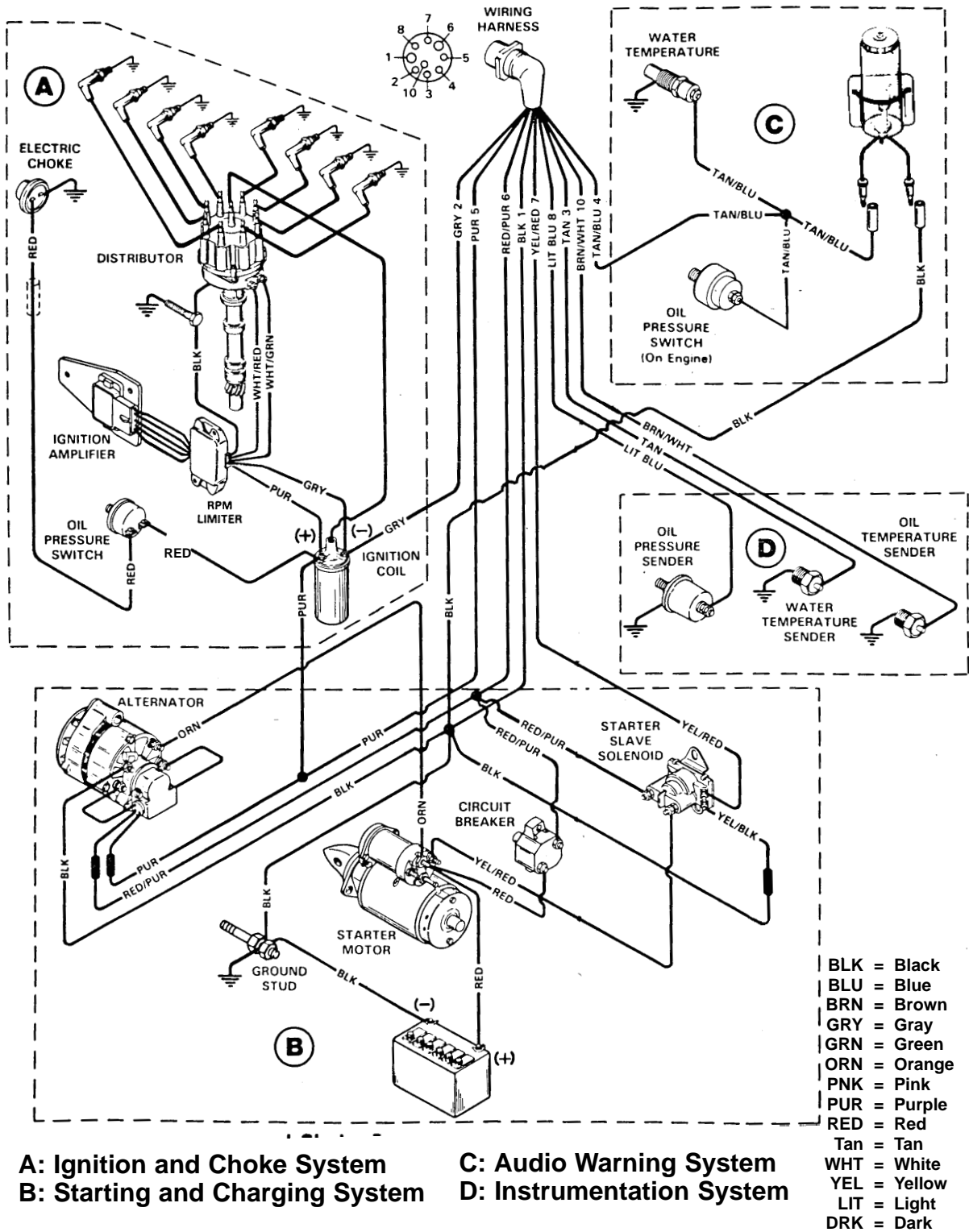

G. COOLING SYSTEM WATER FLOW DIAGRAM - HP 500 (502 CID)

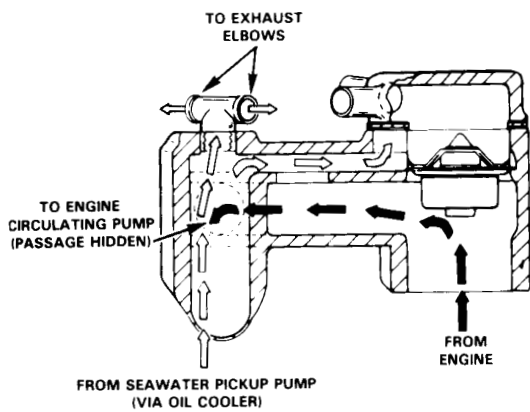
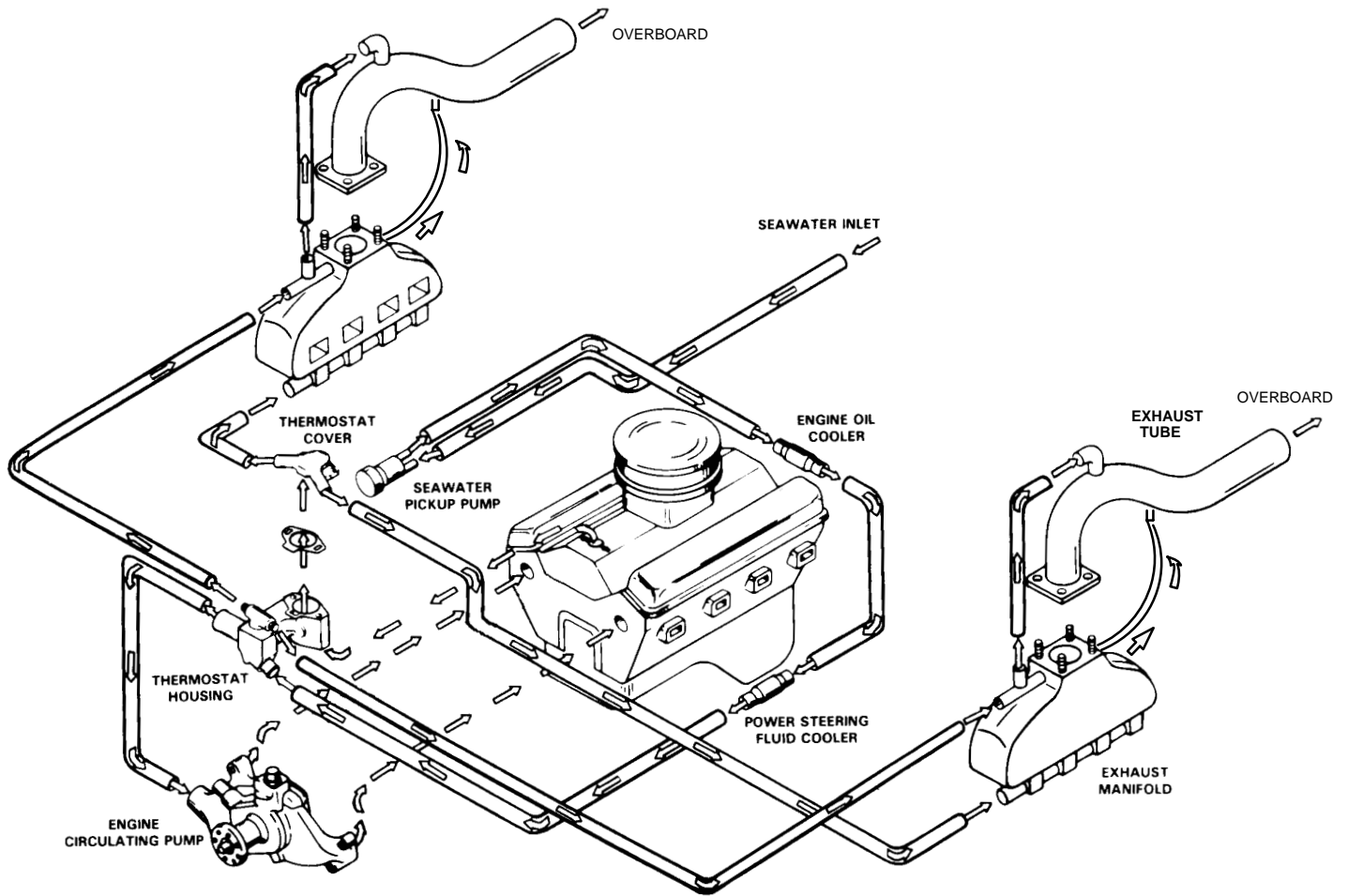

COOLANT FLOW THROUGH THERMOSTAT HOUSING WITH THERMOSTAT CLOSED

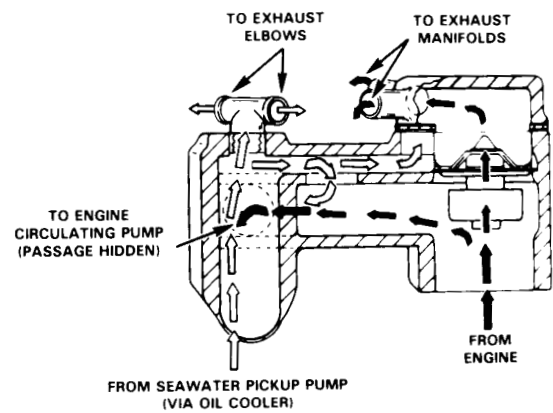
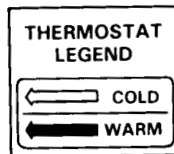

COOLANT FLOW THROUGH THERMOSTAT HOUSING WITH THERMOSTAT OPEN

50743