

TO: SERVICE MANAGER  MECHANICS   
PARTS MANAGER

**REVISED**  
**11-14-94**

**No. 94-4**

## H.P. 600 (502 cid) Specifications S/N D725676 & Up

- A. Tune-up Specifications
- B. Electrical Specifications
- C. Carburetor Specifications
- D. Internal Engine Specifications
- E. Torque Specifications
- F. Wiring Diagram
- G. Water Flow Chart

### A. TUNE-UP SPECIFICATIONS

Horsepower (Kilowatts)	600 (447)
Displacement (Liters)	502 CID (8.2)
Engine Type and Number of Cylinders	V-8
Bore	4.468 in. (113.48mm)
Stroke	4.00 in. (101.6mm)
Compression Ratio	7.5:1
Compression Pressure	135-150 psi (931-1034 kPa)
Ignition	Thunderbolt IV
Spark Plug Type	AC-MR41T, Champion BL4 or NGK 33-813421
Spark Plug Gap	.035 in. (0.9mm)
Timing at Idle RPM (Note)	13° BTDC
Maximum Advance @ 5000 RPM	33° BTDC
Maximum RPM at Wide-Open-Throttle	4800-5200
Idle RPM in Forward Gear	800-850
Firing Order	1-8-4-3-6-5-7-2
Fuel Required	92 Octane {(R+M)÷2} or 98 RON
Fuel Pump Pressure	3-7 psi (10-48 kPa)

*NOTE: Timing should be checked at 5000 RPM. At this RPM, timing should be 33° BTDC. Adjust initial timing to achieve 33° at 5000 RPM.*

Electrical System	12-Volt Negative Ground
Alternator Rating	55 Amperes
Recommended Battery Rating	Min. 450 Amps Cold Cranking Amperage
Crankcase Oil Capacity with New Filter*	8 Qts. (7.5Liters)
Oil Pressure @ 2000 RPM	30-70 psi (207-483 kPa)
Thermostat	143° F (62° C)
Cooling System Capacity	20 U.S. Qts. (18.9L)
*Stern Drive Unit Oil Capacity (Approx.)	III SSM 9.5 Qts. (8.9L) V SSM 6.75 Qts.(6.4L) <b>WITH SPACERS</b> 1 in. (25 mm) - 7.5 Qts. (7.1L) 2 in. (51 mm) - 8.25 Qts. (7.8L) 3 in. (76 mm) - 9 Qts. (8.5L)  VI SSM - 20 U.S. Qts. (19L) <b>WITH SPACERS</b> 1/2in. (13mm) - 20.5 Qts.(19.5L) 1 in. (25 mm) - 21 Qts. (20L) 1-1/2 in. (38mm) - 22 Qts. (20.5L) 2 in. (51 mm) - 23 Qts. (21.75L) 2-1/2 in. (64mm) - 23.5 Qts. (22L) 3 in. (76 mm) - 24 Qts. (23L) 5-3/4 in. (146mm) - 29 Qts. (27.5)
*Transmission Oil Capacity (Approx.)	III-V SSM - 2.1 Qts. (2 L) VI SSM - 2.5 Qts. (2.4 L)

\*Approximately, ALWAYS use dipstick to determine exact quantity of oil required.

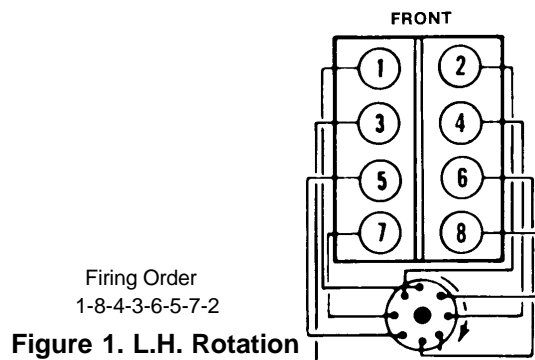

## B. ELECTRICAL SPECIFICATIONS

### Ignition Specifications

Timing	33° BTDC @ 5000 RPM
Coil	Part No. 392-805570A2
Coil Primary Resistance (Ohms) Minimum	.60
Coil Primary Resistance (Ohms) Maximum	.80
Coil Secondary Resistance (Ohms)	9.4-11.7

### Starter Motor Specifications

<b>Mercury Marine Part Number</b>	50-17251A-2			
<b>Delco Remy Part Number</b>	10455603			
<b>Brush Spring Tension</b>	56-105 OZ (1588-2976 g)			
<b>No Load Test</b>				
<b>Volts</b>	<b>Amps. (Min.)</b>	<b>Amps. (Max.)</b>	<b>RPM (Min.)</b>	<b>RPM (max.)</b>
10.6	70	120	5400	10,800

## C. CARBURETOR SPECIFICATIONS

All measurements are ± 1/64 in. (0.4mm).

Make (Model)	Holley (4150)
Part No. Mercury (Holley)	3312-821030a15 (rear) 3312-821030a16 (front) (80466)
Float Adjustment	Bottom of Sight Plug Hole ± 1/32" (.8 mm)
Primary Jets	No. 74
Secondary Jets	No. 84
Accelerator Pump	.015" (.4 mm)
Choke Setting	Index Marks Aligned
Idle Mixture Screw Preliminary Setting	1 turn

## D. INTERNAL ENGINE SPECIFICATIONS

<b>UNIT OF MEASUREMENT in. (mm)</b>
-----------------------------------------

### Cylinder Bore:

Diameter		4.4662-4.4655 (113.442-113.424)
Out of Round	Production	.001 (0.025) Max.
	Service	.002 (0.05) Max.
Taper	Production	Thrust Side .0005 (0.0127) Max.
		Relief Side .001 (0.025) Max.
	Service	.001 (0.025) Max.

### Piston: See Note (1)

Clearance	Production & Service	.0045-.0065 (0.114-0.165)
-----------	-------------------------	---------------------------

NOTE: (1) Measure piston 1/2" (.12 mm) up from bottom of the skirt and 90° from piston pin.

### Piston Ring: (1)HI Production Limit

Compression	Groove Side Clearance	Production	Top	.001-.002 (0.025-0.051)
			2nd	.001-.002 (0.025-0.051)
		Service	.0015-.0025 (0.038-0.064) Max.	
	Gap	Production	Top	.028-.030 (0.711-0.762)
			2nd	.026-.028 (0.660-0.711)
		Service	.028-.032 (0.711-0.813)	
Oil	Groove Side Clearance	Production	.001-.002 (0.025-0.051)	
		Service	.001-.003 (0.025-0.075)	
	Gap	Production	.015-.055 (0.381-1.397)	
		Service	.015-.055 (0.381-1.397)	

**Piston Pin:**

Diameter		.9895-.9898 (0.0251)
Clearance to piston	Production	.00025-.00035 (0.0064-0.0089)
	Service	.0012 (0.030) Max.
Fit in Rod		.0008-.0016 (0.0203-0.0406) Interference

**Crankshaft:**

Main Journal	Diameter	No. 1, 2, 3, 4, 5	2.7482-2.7489 (69.805-69.822)
	Taper & Out of Round	Production	.0005 (0.0127) Max.
Service			.001 (0.025) Max.
Main Bearing Clearance	Production	No. 1, 2, 3, 4	.0025-.003 (0.064-0.076)
		No. 5	.0035-.004 (0.089-0.102)
	Service	No. 1, 2, 3, 4	.0025-.0035 (0.064-0.089)
		No. 5	.0035-.0045 (0.089-0.114)
Crankshaft End Play			.006-.010 (0.152-0.254)
Connecting Rod Journal	Diameter		2.1990-2.2000 (55.855-55.880)
	Taper & Out of Round	Production	.0005 (0.0127)
		Service	.001 (0.025)
Rod Bearing Clearance	Production		.0025-.0035 (0.064-0.089)
	Service		.0025-.0035 (0.064-0.089)
Rod Side Clearance			.013-.023 (0.330-0.584)
Crankshaft Runout @ #3 Main			.005 (0.125) Max

**Camshaft and Drive:**

Lobe Lift ± .002 (0.051 mm)	Intake	.329 (8.36)
	Exhaust	.329 (8.36)
Journal Diameter		1.948-1.949 (49.48-49.51)
Journal Out-of-Round		.0005-.001 (.013-.025)
Camshaft Run-Out		.0005-.001 (.013-.025)
Timing Chain Deflection		.500 (12.7)

### Valve System:

Lifter Type		Hydraulic	
Rocker Arm Ratio		1.7:1	
Valve Lash (Intake & Exhaust)		1/2 to 5/8 Turn Down from Zero Lash	
Face Angle (Intake & Exhaust)		45°	
Seat Angle (Intake & Exhaust)		45°	
Seat Runout (Intake & Exhaust)		.002 (0.050) max.	
Seat Width		Intake	.080 (2.03)
		Exhaust	.080 (2.03)
Stem Clearance	Production	Intake	.0010-.0025 (0.025-0.064)
		Exhaust	.0012-.0025 (0.030-0.064)
	Service	Intake	.0010-.003 (0.025-0.076)
		Exhaust	.0010-.003 (0.025-0.076)
Valve Spring	Free Length		2.20 (55.88)
	Pressure Lbs. @ In (NOTE)	Closed @ 1.875 (47.6)	130 lb. ft. (176 N.m.)
		Open @ 1.316 (33.4)	360 lb. ft. (486 N.m.)
	Installed Height		1.875 (47.6)

NOTE: Test springs as a complete assembly with retainer.

### Cylinder Head:

Gasket Surface Flatness	.006 (0.152) Overall Max. .003 (0.076) within a 6 in. (152 mm) span
-------------------------	------------------------------------------------------------------------

### Flywheel:

Runout	.008 (0.203) Max. (Face Area)
--------	-------------------------------

### E. TORQUE SPECIFICATIONS

Camshaft Sprocket/Gear (NOTE 1)	25 lb.ft. (34 N·m)
Conn. Rod Cap (NOTE 2)	65 lb. ft. (88 N·m)
Crankcase Front Cover	80 lb. in. (9 N·m)
Cylinder Head (NOTE 3)	Step #1-20 lb.ft. (27 Nm.) Step #2-50 lb.ft. (68 Nm.) Step #3-75 lb. ft. (102 Nm.)
Distributor Clamp	15 lb. ft. (20 N·m)
Exhaust Manifold (Bolts)	30 lb. ft. (41 N·m)
Flywheel (NOTE 1)	70 lb. ft. (95 N·m)
Flywheel Drive Plate (NOTE 1)	35 lb. ft. (48 N·m)
Flywheel Housing	30 lb. ft. (41 N·m)
Intake Manifold (NOTE 4)	30 lb. ft. (41 N·m)
Main Bearing Cap	110 lb. ft. (149 N·m)
Oil Pan to Crankcase (5/16-18)	165 lb. in. (19 N·m)
Oil Pan to Crankcase (1/4-20)	80 lb. in. (9 N·m)
Oil Pan Drain Plug	20 lb. ft. (27 N·m)
Oil Pump (NOTE 1)	70 lb. ft. (95 N·m)
Oil Pump Cover (NOTE 1)	80 lb. in. (9 N·m)
Rocker Arm Stud (NOTE 1)	45 lb. ft. (61 N·m)
Rocker Arm Cover	72 lb. in. (8.1 N·m)
Spark Plug	15 lb. ft. (20 N·m)
Torsional Damper	85 lb. ft. (116 N·m)
Water Pump	30 lb. ft. (41 N·m)
Supercharger to Intake Manifold (See Important)	15 lb. ft. (20 N·m)

NOTE 1: Use Loctite 271 (P/N 92-32609-1) on threads.

NOTE 2: Apply engine oil to stud threads and contacting surface of nut.

NOTE 3: Apply moly lube under bolt head, and teflon pipe thread sealant (like Loctite sealant #592) on threads.

NOTE 4: Use only Mercury gasket P/N 27-818188

**IMPORTANT: Torque bolts in 6 increments. After torquing rolling resistance of supercharger should not exceed 20 lb. in. (2.3 N·m).**

**F. ENGINE WIRING DIAGRAM - HP 600SC  
(THUNDERBOLT IGNITION)**

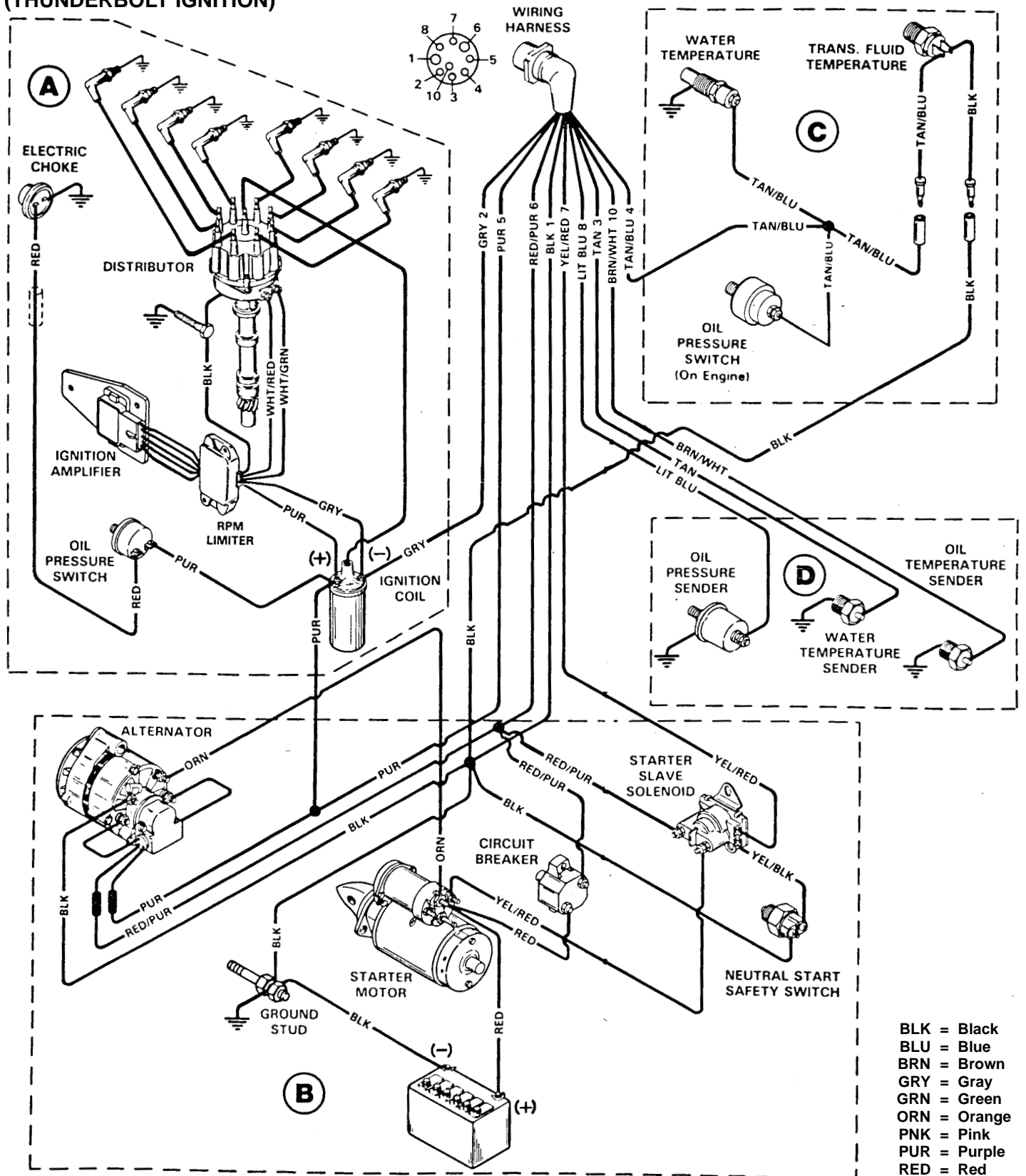

**A: Ignition and Choke System  
B: Starting and Charging System**

**C: Audio Warning System  
D: Instrumentation System**

- BLK = Black
- BLU = Blue
- BRN = Brown
- GRY = Gray
- GRN = Green
- ORN = Orange
- PNK = Pink
- PUR = Purple
- RED = Red
- Tan = Tan
- WHT = White
- YEL = Yellow
- LIT = Light
- DRK = Daek

**G. COOLING SYSTEM WATER FLOW DIAGRAM - HP 600SC  
(STANDARD EXHAUST)**

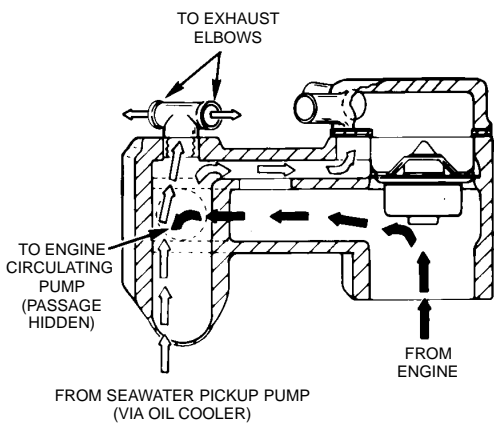
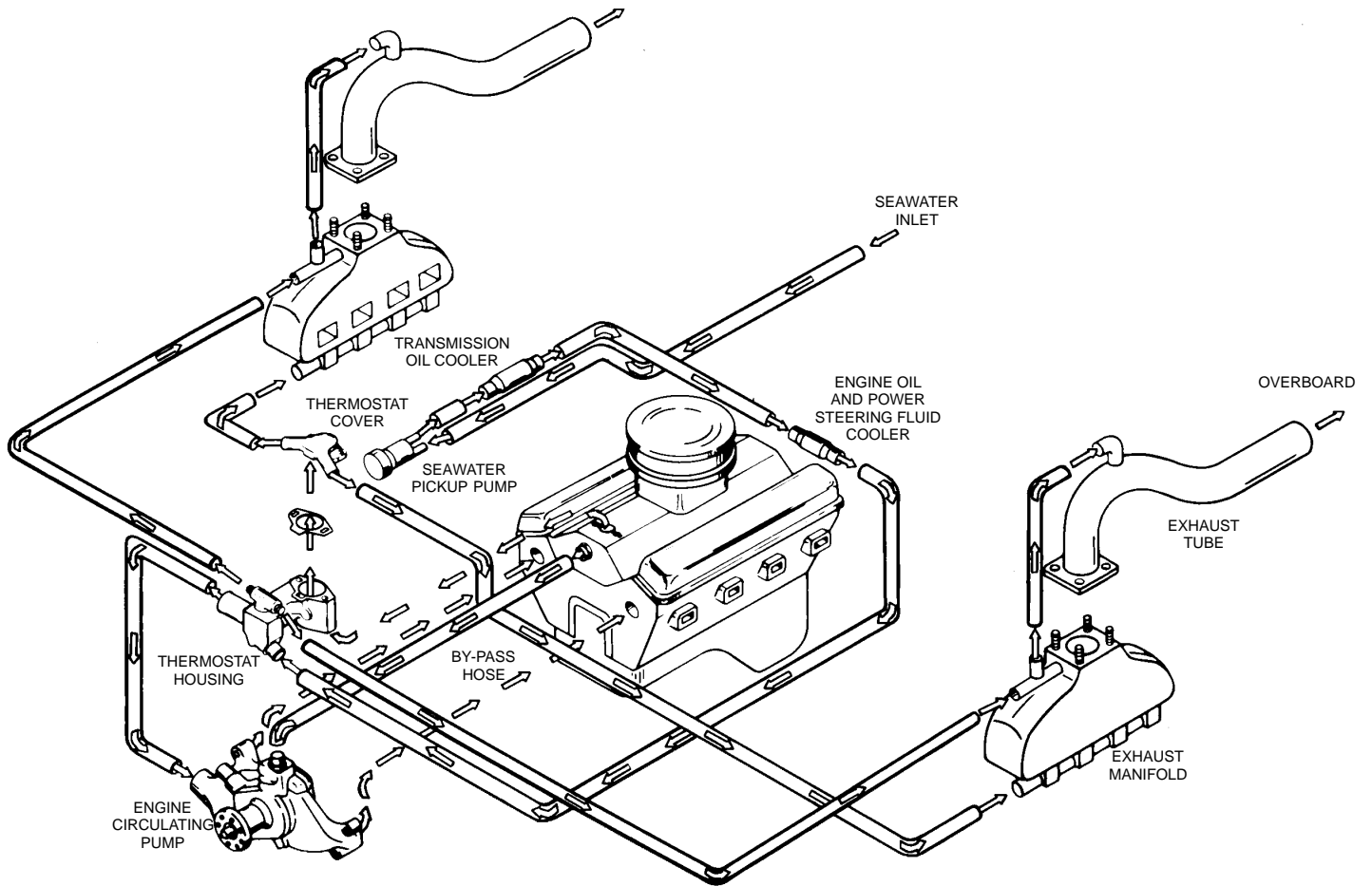

**COOLANT FLOW THROUGH THERMOSTAT HOUSING WITH THERMOSTAT CLOSED**

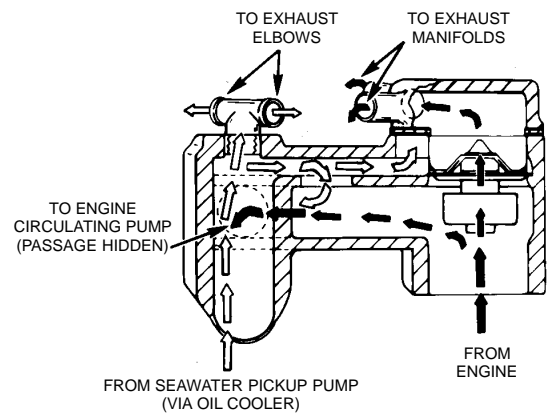
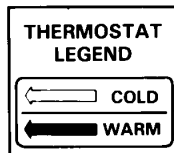

**COOLANT FLOW THROUGH THERMOSTAT HOUSING WITH THERMOSTAT OPEN**