

WARRANTY INFORMATION SERVICE INFORMATION

## Battery Discharge on HP500 EFI Engines

### Models Affected

All HP500 EFI models prior to serial number 0L601357.

### Problem

The engine wiring harness connector plug which attaches to the alternator was incorrectly assembled. The Red/Purple and Purple wires were reversed causing a greater than normal battery draw (in excess of 300 milliamps) with the ignition switch OFF. Normal ignition OFF draw is 20 milliamps.

### Correction

1. Remove the green wiring harness connector plug from the alternator by squeezing the connector lock and pulling on the plug. **Do Not Pull On the Wires going to the plug.**
2. Once removed, verify that the wires are in the wrong location.

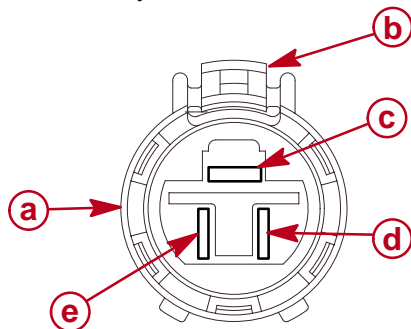

- a** - Face of Wiring Harness Connector Plug
- b** - Connector Lock - Squeeze to Remove Connector Plug from Alternator
- c** - Terminal for Red/Purple Wire (Correct Location)
- d** - Terminal for Purple Wire (Correct Location)
- e** - Open

### SPECIAL TOOL

Use Snap-On tool part number TT600-5 to remove terminals from connector plug.

## CHANGING WIRE LOCATIONS IN CONNECTOR PLUG

1. Using a small flat blade screwdriver, pry the rubber sealing grommet out of the connector plug to expose the wires.

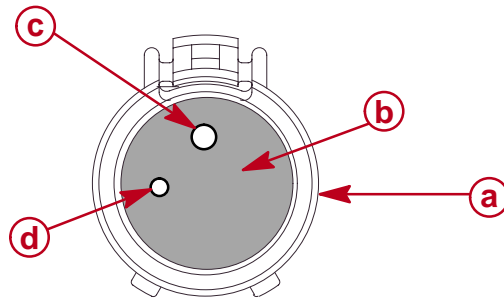

- a** - Connector Plug - Back View
- b** - Rubber Sealing Grommet
- c** - Red/Pur Wire (Correct Location)
- d** - Purple Wire (Correct Location)

2. To release the locking tab on the female terminal, insert Snap On tool P/N TT600-5 into the terminal release slot on the face of the connector while pushing the wire forward in the connector. Once the tool is fully inserted and the tab released, remove the wire terminal from the connector plug. Remove second wire terminal from connector plug.

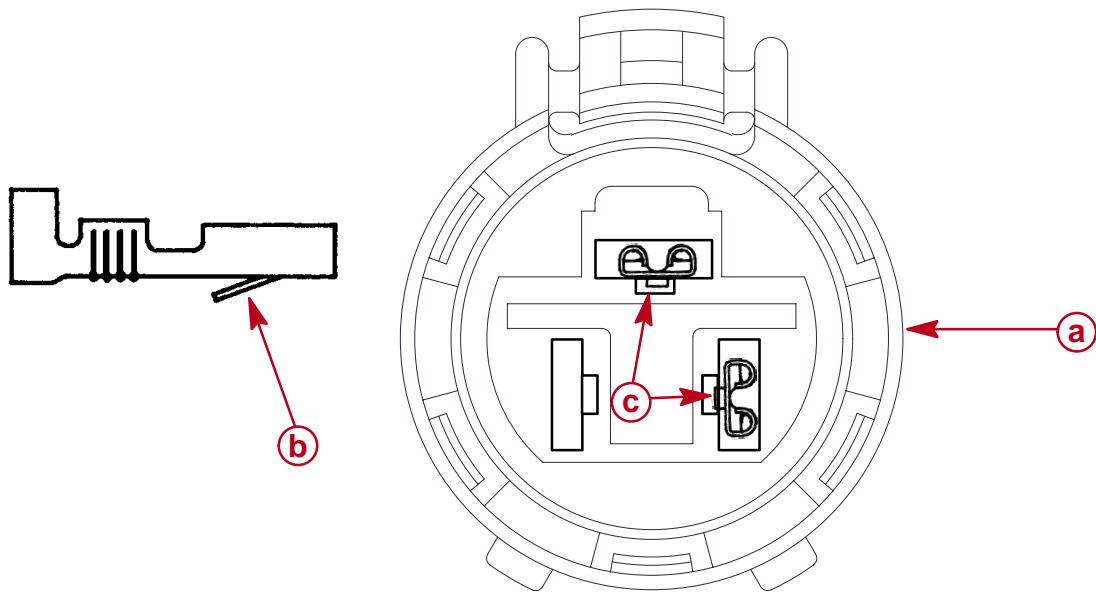

- a** - Connector Plug Face
- b** - Terminal Locking Tab
- c** - Terminal Release Slot

3. Pry terminal lock tabs back into the locking position. Install the Red/Pur wire into the connector in the slot closest to the connector lock release and the Purple into the slot on the right side when looking at the face of the connector plug.

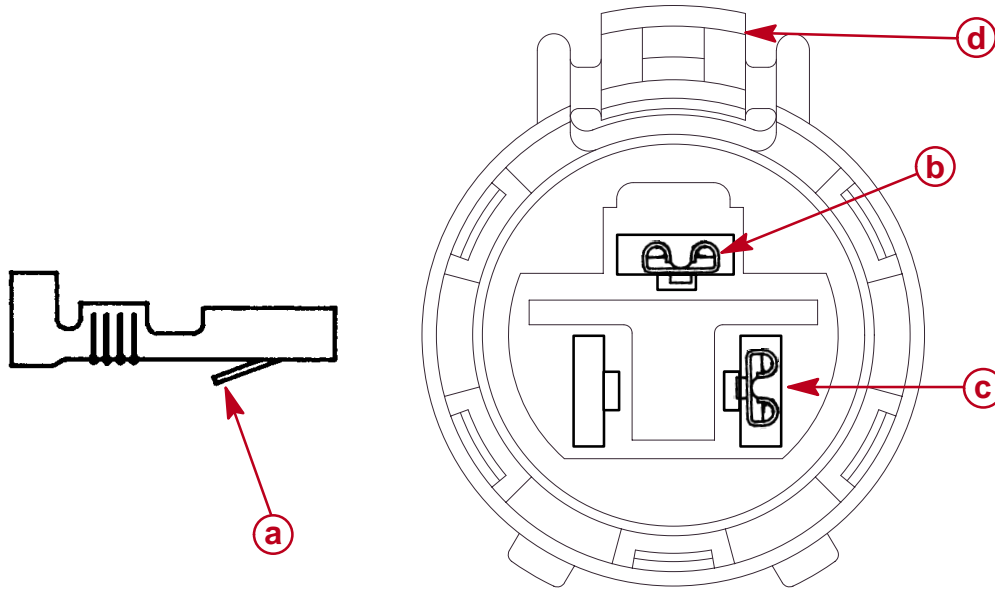

- a** - Locking Tab on Terminal - Pry Back Into Locking Position
- b** - Red/Pur Lead
- c** - Purple Lead
- d** - Connector Lock Release

4. Slide Rubber protective grommet back into the plug connector and insert connector back into the alternator.

## Warranty Information

Fill out a warranty claim form listing the following information:

Engine Serial Number

Part Failure Code: 331

UFO Failure Code: 00

Flat Rate Code & Time: EXCP (0.8 hrs.)

**IMPORTANT: If the engine is no longer within the 1 year MerCruiser Limited Warranty Period, the claim will be handled as a customer relations adjustment.**